

Introduction

Thank you for your purchase of CD 1118.

This Operation Guide is intended to help you operate the machine correctly, perform routine maintenance and take a simple troubleshooting action as necessary, so that you can always use the machine in good condition. Please read this Operation Guide before you start using the machine, and keep it close to the machine for easy reference. We recommend the use of our own brand supplies. We will not be liable for any damage caused by the use of third party supplies in this machine.

CONTENTS

1	Names of Parts	1-1
	Main Body	1-1
2	Preparations	2-1
	Loading Paper	2-1
	Loading Paper into the Cassette	2-2
	Cassette Size Detection	2-4
	Setting Paper in the Multi Purpose Tray	2-4
	Loading postcards or envelopes in the MP tray	2-7
	MP Tray Size and Media Type	2-8
	Selecting a Size from Regular Sizes	2-8
	Selecting a Size from Other Regular Sizes	2-8
	Specifying Custom Paper Size	2-9
	Selecting Special Paper Type	2-9
	Loading Originals	2-10
	Placing Originals on the Platen	2-10
	Loading Originals in the Document Processor	2-11
	Originals Supported by the Document Processor	2-11
	Originals Not Supported by the Document Processor	2-11
	Part Names of the Document Processor	2-11
	How to Load Originals	2-12
	Turning Power On	2-13
	User Interface language	2-14
3	Basic Operation	3-1
	Basic Copying Procedure	3-1
	Zoom Copying	3-3
	3-3
	Auto Zoom	3-3
	Manual Zoom	3-4
	Duplex Copying	3-5
	2-Sided Copy Reverse Side Rotation Setting	3-7
	Split Copying	3-8
	Two-sided to One-sided	3-8
	Book to One-sided	3-8
	Collated Copying	3-9
	Combined Copying	3-10
	2-in-1	3-11
	4-in-1 (horizontal)	3-12
	4-in-1 (vertical)	3-13
	Interrupt Copying	3-14
	Low Power Mode	3-15
	Auto Sleep	3-16
	3-16
4	Job Accounting	4-1
	Overview of Job Accounting	4-1
	Job Accounting Operation Procedures	4-2
	Department ID Code Registration	4-2
	Deleting Department ID Codes	4-3
	Clearing the Job Accounting Count	4-3
	Printing the Job Accounting List	4-3
	How to set Job Accounting	4-4
	Making copies in Job Accounting Mode	4-4

5	Optional Equipment	5-1
	Document Processor	5-1
	Paper Feeder	5-2
	Duplex Unit	5-2
	Key Counter	5-3
	Printer Kit / Printer Server	5-3
	Additional Memory	5-3
6	Maintenance	6-1
	Cleaning the Machine	6-1
	Replacing the Toner Container and the Waste Toner Box	6-5
7	Troubleshooting	7-1
	If Trouble Occurs	7-1
	Notes	7-8
	Removal Procedures	7-8
Appendix	Appendix-1
	Specifications	Appendix-1
	Main Body	Appendix-1
	Copier Functions	Appendix-2
	Document Processor (optional)	Appendix-2
	Paper Feeder (optional)	Appendix-2
	Duplex Unit (optional)	Appendix-3
	Environmental Specifications	Appendix-3
Index	Index-1

Notice The information in this guide is subject to change without notification. Additional pages may be inserted in future editions. The user is asked to excuse any technical inaccuracies or typographical errors in the present edition.

No responsibility is assumed if accidents occur while the user is following the instructions in this guide.

This guide, any copyrightable subject matter sold or provided with or in connection with the sale of the machine, are protected by copyright. All rights are reserved. Copying or other reproduction of all or part of this guide, any copyrightable subject matter without the prior written consent of UTAX GmbH is prohibited. Any copies made of all or part of this guide, any copyrightable subject must contain the same copyright notice as the material from which the copying is done.

Regarding Tradenames

ENERGY STAR is a U.S. registered mark. All other brand and product names are registered trademarks or trademarks of their respective companies.

Legal Restriction On Copying

- It may be prohibited to copy copyrighted material without permission of the copyright owner.
- It is prohibited under any circumstances to copy domestic or foreign currencies and securities, etc., including: Paper money, Bank notes, Securities, Stamps, Passports, Certificates
- Local laws and regulations may prohibit or restrict copying or scanning of other items not mentioned above.

Energy Saving Control Function



The device comes equipped with a **Low Power Mode** where energy consumption is reduced after a certain amount of time elapses since the device was last used, as well as a **Sleep Mode** where printer and fax functions remain in a waiting state but power consumption is still reduced to a minimum when there is no activity with the device within a set amount of time. If the auto low power time is equal to the auto sleep time, a Sleep Mode is preceded.

Low Power Mode

The device automatically enters Low Power Mode when one minute has passed since the device was last used. The amount of time of no activity that must pass before Low Power Mode is activated may be lengthened.

Sleep Mode

The device automatically enters Sleep Mode when one minute has passed since the device was last used. The amount of time of no activity that must pass before Sleep Mode is activated may be lengthened. For more information see **Auto Sleep** on page **3-16**.

Optional Automatic 2-Sided Copy Function

This device can include a 2-sided copying as an optional function. For example, by copying two 1-sided originals onto a single sheet of paper as a 2-sided copy, it is possible to lower the amount of paper used.

Paper Recycling

This device supports the recycled paper which reduces the load on the environment. Your sales or service representative can provide information about recommended paper types.

Energy Star (ENERGY STAR®) Program

We have determined as a participating company in the International Energy Star Program that this product is compliant with the standards laid out in the International Energy Star Program.

Please read this Operation Guide before using this machine. Keep it close to the machine for easy reference.

The sections of this guide and parts of the machine marked with symbols are safety warnings meant to protect the user, other individuals and surrounding objects, and ensure correct and safe usage of the machine. The symbols and their meanings are indicated below.



DANGER: Indicates that serious injury or even death will very possibly result from insufficient attention to or incorrect compliance with the related points.



WARNING: Indicates that serious injury or even death may result from insufficient attention to or incorrect compliance with the related points.



CAUTION: Indicates that personal injury or mechanical damage may result from insufficient attention to or incorrect compliance with the related points.

Symbols

The  symbol indicates that the related section includes safety warnings. Specific points of attention are indicated inside the symbol.



.... [General warning]



.... [Warning of danger of electrical shock]



.... [Warning of high temperature]

The  symbol indicates that the related section includes information on prohibited actions. Specifics of the prohibited action are indicated inside the symbol.



.... [Warning of prohibited action]



.... [Disassembly prohibited]

The ● symbol indicates that the related section includes information on actions which must be performed. Specifics of the required action are indicated inside the symbol.



.... [Alert of required action]



.... [Remove the power plug from the outlet]



.... [Always connect the machine to an outlet with a ground connection]

Please contact your service representative to order a replacement if the safety warnings in this Operation Guide are illegible or if the guide itself is missing. (fee required)

IMPORTANT! PLEASE READ FIRST.

CAUTION LABELS

Caution labels have been attached to the machine at the following locations for safety purposes. Be sufficiently careful to avoid fire or electric shock when removing a paper jam or when replacing toner.

Label 2

High temperature inside. Do not touch parts in this area, because there is a danger of getting burned.



Label 3

Do not attempt to incinerate the toner container. Dangerous sparks may cause burns.

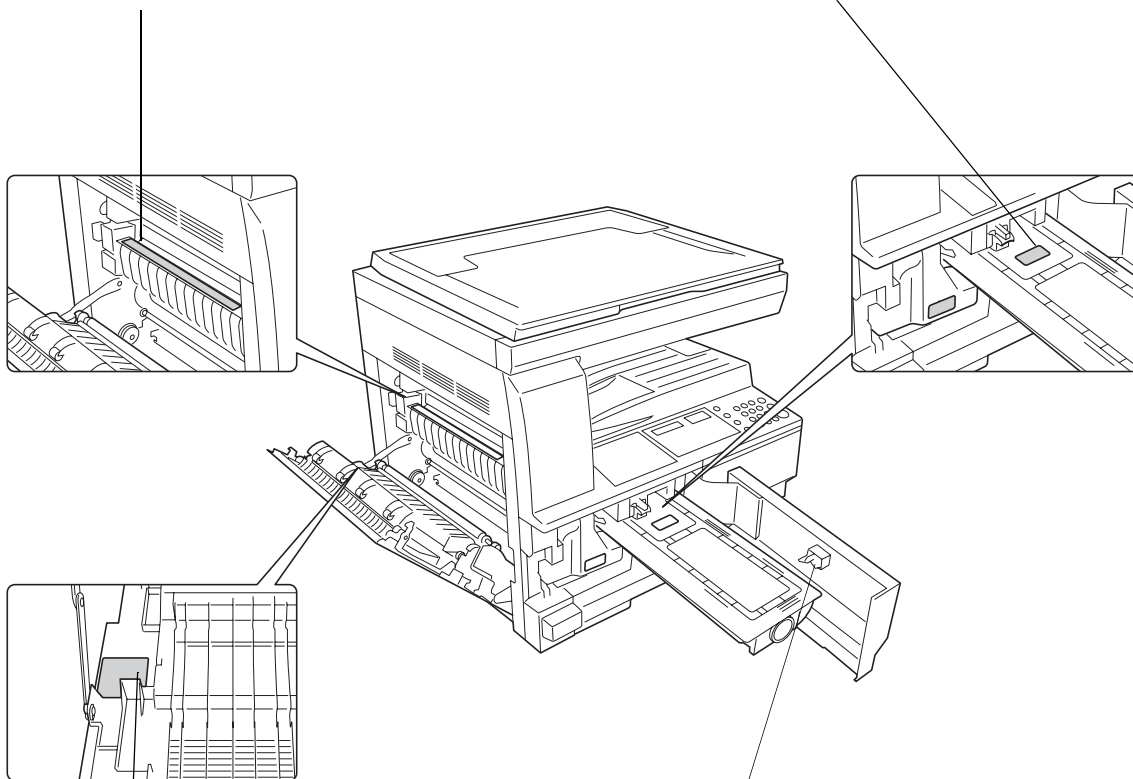

Label 1

High temperature inside. Do not touch parts in this area, because there is a danger of getting burned.



Label 4

Do not attempt to incinerate the waste toner box. Dangerous sparks may cause burns.



NOTE: Do not remove these labels.



INSTALLATION PRECAUTIONS

Environment



Caution

Avoid placing the machine on or in locations which are unstable or not level. Such locations may cause the machine to fall down or fall over. This type of situation presents a danger of personal injury or damage to the machine.

Avoid locations with humidity or dust and dirt. If dust or dirt become attached to the power plug, clean the plug to avoid the danger of fire or electrical shock.

Avoid locations near radiators, heaters, or other heat sources, or locations near flammable items, to avoid the danger of fire.

To keep the machine cool and facilitate changing of parts and maintenance, allow access space as shown below. Leave adequate space, especially around the vents, to allow air to be properly ventilated out of the machine.

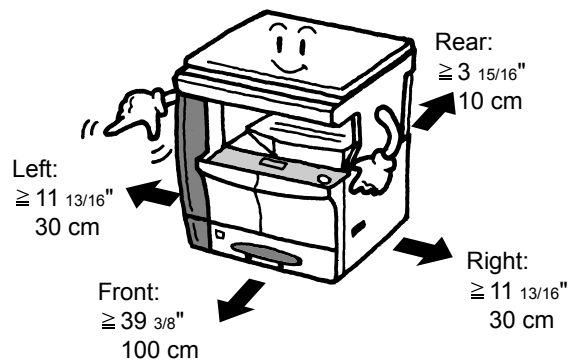
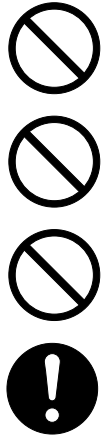

Other precautions

Adverse environmental conditions may affect the safe operation and performance of the machine. Install in an air-conditioned room (recommended room temperature: around 50-90,5 °F (10-32,5 °C), humidity: around 15-80 %), and avoid the following locations when selecting a site for the machine.

- Avoid locations near a window or with exposure to direct sunlight.
- Avoid locations with vibrations.
- Avoid locations with drastic temperature fluctuations.
- Avoid locations with direct exposure to hot or cold air.
- Avoid poorly ventilated locations.

If the floor is delicate, when this product is moved after installation, the floor material may be damaged.

During copying, some ozone is released, but the amount does not cause any ill effect to one's health. If, however, the machine is used over a long period of time in a poorly ventilated room or when making an extremely large number of copies, the smell may become unpleasant. To maintain the appropriate environment for copy work, it is suggested that the room be properly ventilated.

Power supply/Grounding the machine

Warning

Do not use a power supply with a voltage other than that specified. Avoid multiple connections in the same outlet. These types of situations present a danger of fire or electrical shock.



Plug the power cord securely into the outlet. If metallic objects come in contact with the prongs on the plug, it may cause a fire or electric shock.



Always connect the machine to an outlet with a ground connection to avoid the danger of fire or electrical shock in case of an electric short. If an earth connection is not possible, contact your service representative.



Other precautions

Connect the power plug to the closest outlet possible to the machine.

The power supply cord is used as the main disconnect device. Ensure that the socket/outlet is located/installed near the equipment and is easily accessible.

Handling of plastic bags

Warning

Keep the plastic bags that are used with the machine away from children. The plastic may cling to their nose and mouth causing suffocation.



PRECAUTIONS FOR USE

Cautions when using the machine

Warning

Do not place metallic objects or containers with water (flower vases, flower pots, cups, etc.) on or near the machine. This situation presents a danger of fire or electrical shock should they fall and spill liquids inside.



Do not remove any of the covers from the machine as there is a danger of electrical shock from high voltage parts inside the machine.



Do not damage, break or attempt to repair the power cord. Do not place heavy objects on the cord, pull it, bend it unnecessarily or cause any other type of damage. These types of situations present a danger of fire or electrical shock.



Never attempt to repair or disassemble the machine or its parts as there is a danger of fire, electrical shock or damage to the laser. If the laser beam escapes, there is a danger of it causing blindness.



If the machine becomes excessively hot, smoke appears from the machine, there is an odd smell, or any other abnormal situation occurs, there is a danger of fire or electrical shock. Turn the main power switch off (O) immediately, be absolutely certain to remove the power plug from the outlet and then contact your service representative.



If anything harmful (paper clips, water, other fluids, etc.) falls into the machine, turn the main power switch off (O) immediately. Next, be absolutely certain to remove the power plug from the outlet to avoid the danger of fire or electrical shock. Then contact your service representative.



Do not remove or connect the power plug with wet hands, as there is a danger of electrical shock.



Always contact your service representative for maintenance or repair of internal parts.



Caution

Do not pull the power cord when removing it from the outlet. If the power cord is pulled, the wires may become broken and there is a danger of fire or electrical shock. (always grasp the power plug when removing the power cord from the outlet.)



Always remove the power plug from the outlet when moving the machine. If the power cord is damaged, there is a danger of fire or electrical shock.



If the machine will not be used for a short period of time (overnight, etc.), turn the main power switch off (O). If it will not be used for an extended period of time (vacations, etc.), remove the power plug from the outlet for safety purposes during the time the machine is not in use.



Always hold the designated parts only when lifting or moving the machine.



For safety purposes, always remove the power plug from the outlet when performing cleaning operations.



If dust accumulates within the machine, there is a danger of fire or other trouble. It is therefore recommended that you consult with your service representative in regard to cleaning of internal parts. This is particularly effective if accomplished prior to seasons of high humidity. Consult with your service representative in regard to the cost of cleaning the internal parts of the machine.



Other precautions

Do not place heavy objects on the machine or cause other damage to the machine.

Do not open the upper front cover, turn off the main power switch, or pull out the power plug during copying.

When lifting or moving the machine, contact your service representative.

Do not touch electrical parts, such as connectors or printed circuit boards. They could be damaged by static electricity.

Do not attempt to perform any operations not explained in this handbook.

Caution: Use of controls or adjustments or performance of procedures other than those specified herein may result in hazardous radiation exposure.

Do not look directly at the light from the scanning lamp as it may cause your eyes to feel tired or painful.

Cautions when handling consumables

Caution

Do not attempt to incinerate the toner container or the waste toner box. Dangerous sparks may cause burns.



Keep the toner container and the waste toner box out of the reach of children.



If toner happens to spill from the toner container or the waste toner box, avoid inhalation and ingestion, as well as contact with your eyes and skin.



- If you do happen to inhale toner, move to a place with fresh air and gargle thoroughly with a large amount of water. If coughing develops, contact a physician.
- If you do happen to ingest toner, rinse your mouth out with water and drink 1 or 2 cups of water to dilute the contents of your stomach. If necessary, contact a physician.
- If you do happen to get toner in your eyes, flush them thoroughly with water. If there is any remaining tenderness, contact a physician.
- If toner does happen to get on your skin, wash with soap and water.

DO NOT attempt to force open or destroy the toner container or the waste toner box.



Other precautions

After use, ALWAYS dispose of the toner container and the waste toner box in accordance with Federal, State and Local rules and regulations.

Store all consumables in a cool, dark location.

If you will not be using the copier for a prolonged period of time, remove all paper from the cassette and the multi-purpose tray and seal in its original packaging.

Handling of plastic bags

WARNING

Keep the plastic bags that are used with the machine away from children. The plastic may cling to their nose and mouth causing suffocation.



SAFETY OF LASER BEAM

1. Safety of laser beam

This machine has been certified by the manufacturer to Class 1 level under the radiation performance standards established by the U.S. DHHS (Department of Health and Human Services) in 1968. This indicates that the product is safe to use during normal operation and maintenance. The laser optical system, enclosed in a protective housing and sealed within the external covers, never permits the laser beam to escape.

2. The CDRH Act

A laser-product-related act was implemented on Aug. 2, 1976, by the Center for Devices and Radiological Health (CDRH) of the U.S. Food and Drug Administration (FDA). This act prohibits the sale of laser products in the U.S. without certification, and applies to laser products manufactured after Aug. 1, 1976. The label shown below indicates compliance with the CDRH regulations and must be attached to laser products marketed in the United States. On this machine, the label is on the right.

3. Optical unit

When checking the optical unit, avoid direct exposure to the laser beam, which is invisible. Shown at below is the label located on the cover of the optical unit.

4. Maintenance

For safety of the service personnel, follow the maintenance instructions in the other section of this manual.

5. Safety switch

The power to the laser unit is cut off when the front cover is opened.

Safety Instructions Regarding the Disconnection of Power

Caution: The power plug is the main isolation device! Other switches on the equipment are only functional switches and are not suitable for isolating the equipment from the power source.

VORSICHT: Der Netzstecker ist die Hauptisoliervorrichtung! Die anderen Schalter auf dem Gerät sind nur Funktionsschalter und können nicht verwendet werden, um den Stromfluß im Gerät zu unterbrechen.

Safety Instructions Regarding the Disconnection of Power

Caution: The power plug is the main isolation device! Other switches on the equipment are only functional switches and are not suitable for isolating the equipment from the power source.

Attention: Le débranchement de la fiche secteur est le seul moyen de mettre l'appareil hors tension. Les interrupteurs sur l'appareil ne sont que des interrupteurs de fonctionnement: ils ne mettent pas l'appareil hors tension.

WARNING

This equipment has been tested and found to comply with the limits for a Class B digital device, pursuant to Part 15 of the FCC Rules. These limits are designed to provide reasonable protection against harmful interference in a residential installation. This equipment generates, uses and can radiate radio frequency energy and, if not installed and used in accordance with the instructions, may cause harmful interference to radio communications. However, there is no guarantee that interference will not occur in a particular installation. If this equipment does cause harmful interference to radio or television reception, which can be determined by turning the equipment off and on, the user is encouraged to try to correct the interference by one or more of the following measures:

- Reorient or relocate the receiving antenna.
- Increase the separation between the equipment and receiver.
- Connect the equipment into an outlet on a circuit different from that to which the receiver is connected.
- Consult the dealer or an experienced radio/TV technician for help.
- The use of a non-shielded interface cable with the referenced device is prohibited.

CAUTION — The changes or modifications not expressly approved by the party responsible for compliance could void the user's authority to operate the equipment.

This device complies with Part 15 of FCC Rules and RSS-Gen of IC Rules.

Operation is subject to the following two conditions; (1) this device may not cause interference, and (2) this device must accept any interference, including interference that may cause undesired operation of the device.

* The above warning is valid only in the United States of America.

Radio Tag Technology

In some countries the radio tag technology used in this equipment to identify the toner container may be subject to authorization and the use of this equipment may consequently be restricted.

MERCURY WARNING



THE LAMP(S) INSIDE THIS PRODUCT CONTAIN MERCURY AND MUST BE RECYCLED OR DISPOSED OF ACCORDING TO LOCAL, STATE OR FEDERAL LAWS.

Other precautions (for users in California, the United States)

This product contains a CR Coin Lithium Battery which contains Perchlorate Material - special handling may apply. See www.dtsc.ca.gov/hazardouswaste/perchlorate.



**DECLARATION OF CONFORMITY
TO
89/336/EEC, 73/23/EEC and 93/68/EEC**

We declare under our sole responsibility that the product to which this declaration relates is in conformity with the following specifications.

Limits and methods of measurement for immunity characteristics of information technology equipment	EN55024
Limits and methods of measurement for radio interference characteristics of information technology equipment	EN55022 Class B
Limits for harmonic currents emissions for equipment input current $\leq 16A$ per phase	EN61000-3-2
Limitation of voltage fluctuations and flicker in low-voltage supply systems for equipment with rated current $\leq 16A$	EN61000-3-3
Safety of information technology equipment, including electrical equipment	EN60950
Radiation Safety of laser products, equipment classification, requirements and user's guide	EN60825-1

Guide to this Operation Guide

This operation guide has the following chapters. The content of these chapters is summarized below to be used as a reference.

1 Names of Parts

This chapter contains explanations on the names and functions of the parts of the machine and its operation panel.

2 Preparations

This chapter contains explanations on procedures for loading paper and connection of this product.

3 Basic Operation

This chapter contains explanations on the basic procedures of simple copying and printing.

4 Job Accounting

This chapter explains the job accounting functions of this machine.

5 Optional Equipment

This chapter contains explanations on the optional equipment that can be used with this product.

6 Maintenance

This chapter contains explanations on replacement of the toner container and the waste toner box and maintenance of this product.

7 Troubleshooting

This chapter contains explanations on handling problems that may occur, for example, when an error message appears or if a paper jam occurs.

Appendix

The appendix explains the specifications of this product.

Conventions in This Guide

The following conventions are used depending on the nature of the description.

Convention	Description	Example
[Bold]	Indicates the operation panel keys or a computer screen.	Press [OK] .
<i>Italic</i>	Indicates a message displayed on the touch panel.	<i>Ready to copy</i> is displayed.
	Used to emphasize a key word, phrase or references to additional information.	For more information refer to <i>Sleep and Auto Sleep on page 3-5</i> .
Note	Indicates supplemental information or operations for reference.	NOTE:
Important	Indicates items that are required or prohibited so as to avoid problems.	IMPORTANT:
Caution	Indicates what must be observed to prevent injury or machine breakdown and how to deal with it.	CAUTION:

Originals and Paper Sizes

This section explains the notation used in this guide when referring to sizes of originals or paper sizes.

As with A4, B5 and Letter, which may be used either in the horizontal or vertical direction, horizontal direction is indicated by an additional letter R in order to indicate the orientation of the original/paper.

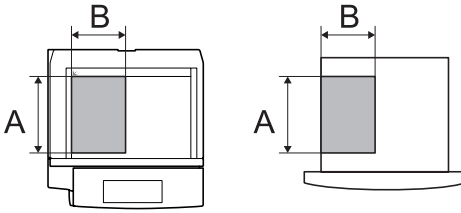
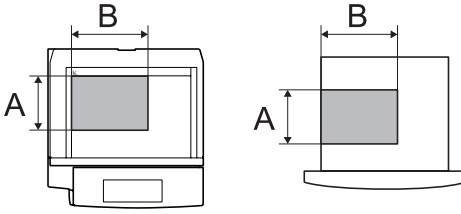
Placement direction	Indicated size*
<p>Vertical direction</p>  <p>Original Paper</p> <p>For the originals/paper, dimension A is longer than B.</p>	<p>A4, B5, A5, B6, A6, 16K, Letter, Statement</p>
<p>Horizontal direction</p>  <p>Original Paper</p> <p>For the originals/paper, dimension A is shorter than B.</p>	<p>A4-R, B5-R, A5-R, B6-R, A6-R, 16K-R, Letter-R, Statement-R</p>

* The size of the original/paper that can be used depends on the function and source tray. For further details, refer to the page detailing that function or source tray.

1 Names of Parts

Main Body

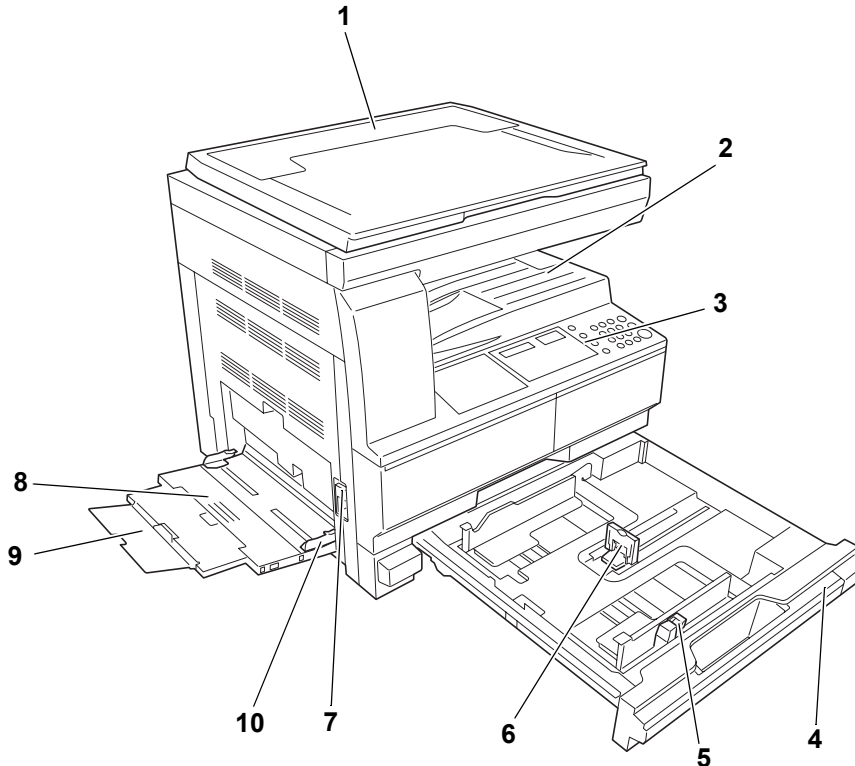

- 1 **Original cover** — Open/close this cover when setting the original on the platen.
- 2 **Output tray** — Finished copies or printouts are stored on this tray. The output tray has a storage capacity of 250 sheets of standard paper (80 g/m²).
- 3 **Operation panel** — Perform operations from the main body here.
- 4 **Cassette** — This cassette has a storage capacity of 300 sheets of standard paper (80 g/m²).
- 5 **Paper width adjusting tab** — Use this tab to adjust the paper width guides to fit to the width of the paper to be loaded in the cassette.
- 6 **Paper length adjusting tab** — Adjust this tab to adjust the paper length guide to fit to the length of the paper to be loaded in the cassette.
- 7 **Left cover handle** — Pull this handle up to open the left cover.
- 8 **Multi-purpose tray** — When using small paper or special paper, set the paper here.
- 9 **MP tray extension** — Pull this to use when setting A4R paper or larger paper.
- 10 **Slider** — Adjust this to fit to the width of paper to be set in the multi-purpose tray.

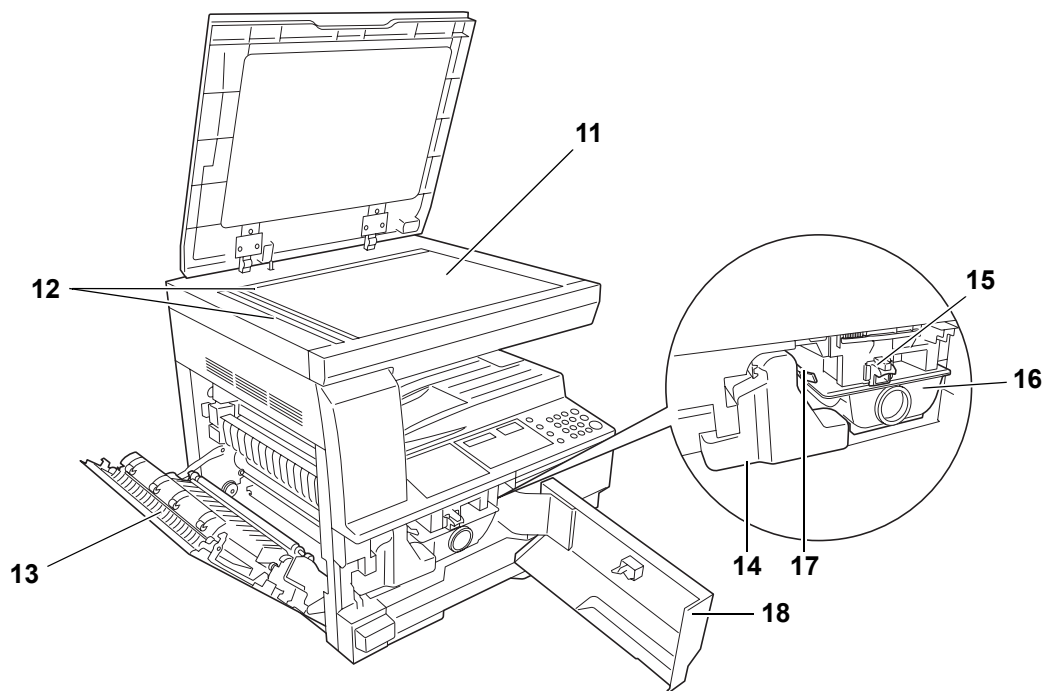

- 11 **Platen** — Set an original here for copying. Be sure to lay the original face-down and align the edge of the original flush up against the left rear corner of the platen.
- 12 **Original size indicator plates** — Be sure to set an original along these plates when setting it on the platen.
- 13 **Left cover** — Open this cover if a paper jam occurs inside the machine.
- 14 **Waste toner box**
- 15 **Toner container release lever** — Operate this lever when replacing the toner container.
- 16 **Toner container**
- 17 **Charger cleaner rod** — Pull this rod and then push it back again after replacing the toner container or when images become dirty.
- 18 **Front cover** — Open this cover when replacing the toner container and the waste toner box or when cleaning this machine.

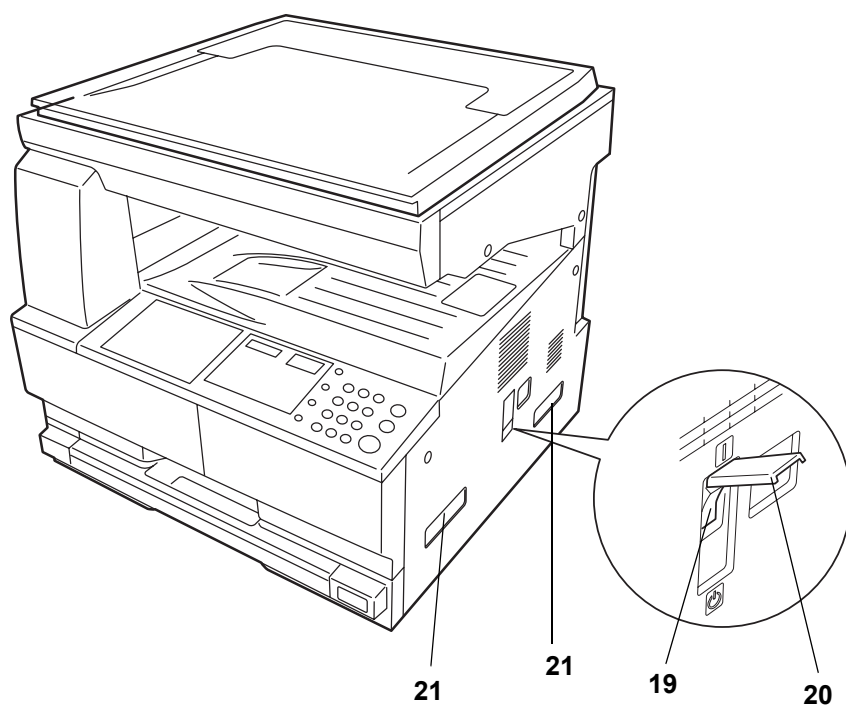

- 19 Main power switch** — Turn this switch on (|) before using this machine.
- 20 Main power switch cover** — Open to operate the main power switch.
- 21 Handles for transport** — Hold the four recessed portions at the right and left when transporting this machine.

Operation Panel

US model

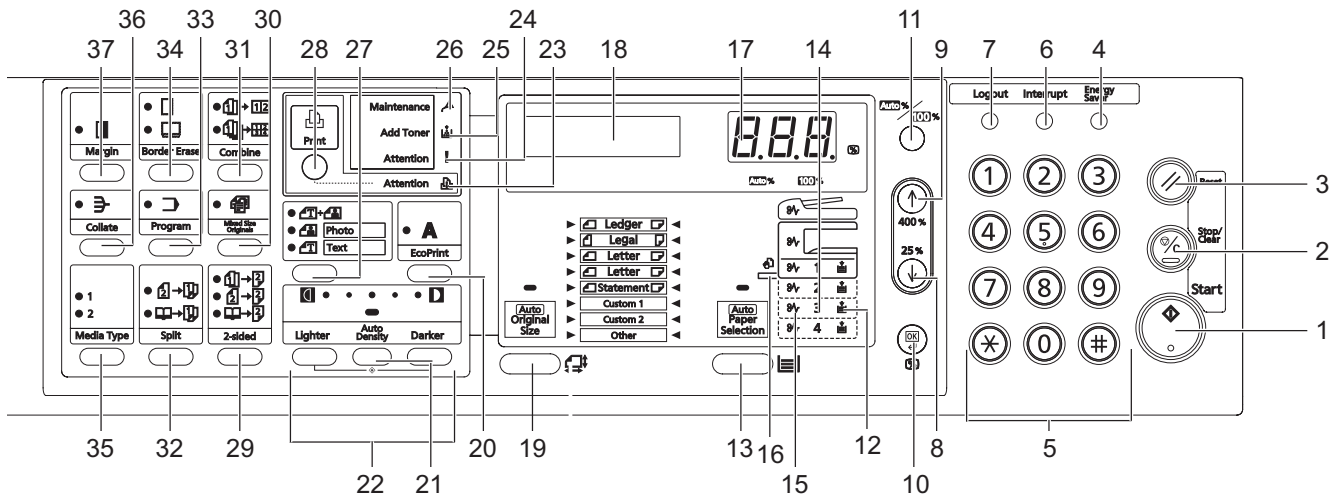

- 1 Start Key (Indicator)
- 2 Stop/Clear Key
- 3 Reset Key
- 4 Energy Saver Key
- 5 Numeric keys
- 6 Interrupt Key
- 7 Logout Key
- 8 ↓ Key
- 9 ↑ Key
- 10 OK Key
- 11 /Auto%100% Key
- 12 Paper Supply Indicator
- 13 Paper Selection Key
- 14 Paper Supply Level Indicator
- 15 Paper Misfeed Indicator
- 16 MP Indicator
- 17 No. of Copies/Zoom Display
- 18 Message Display
- 19 Original Size Key
- 20 EcoPrint Key
- 21 Auto Density Key
- 22 Density Adjustment Key/Density Display

European model

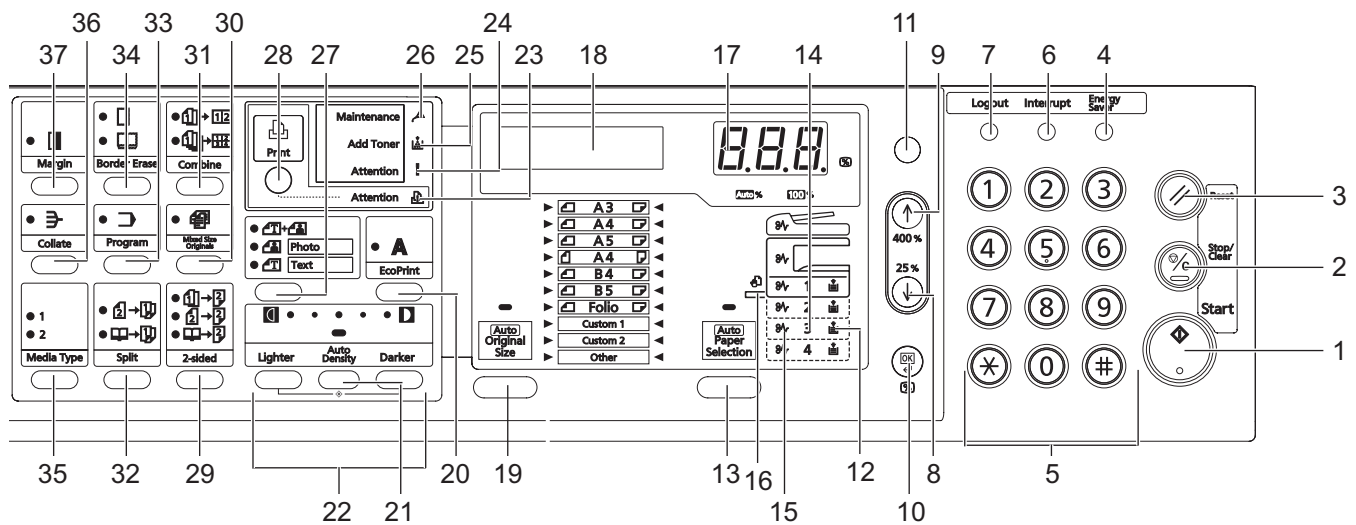

- 23 Attention Indicator**
- 24 Error Indicator**
- 25 Add Toner Indicator**
- 26 Maintenance Indicator**
- 27 Image Quality Selection Key**
- 28 Printer Key (Indicator)**
Press this to switch the message display between copier mode and printer mode, when the optional printer kit is installed.
- 29 2-sided Key**
- 30 Mixed Original Size Key**
- 31 Combine Key**
- 32 Split Key**
- 33 Program Key**
- 34 Border Erase Key**
- 35 Media Type Key**
- 36 Collate Key**
- 37 Margin Key**

Message Display

The message display on the operation panel shows:

- Status information, the messages listed below which are displayed during normal operation.
- Error codes, when the printer requires the operator’s attention, refer to chapter „Troubleshooting“.

Status Information

Message	Meaning
Self test	The copier is performing self-diagnostics after power-up.
Please wait.	The copier is warming up and is not ready. When the copier is switched on for the first time, this message will take approximately 20 seconds.
Ready to copy.	The copier is ready to copy.

Error codes

Refer to chapter „Troubleshooting“.

System Menu (the mode after warm-up processing has been completed or Reset key was pressed)

The copier has been set at the factory to automatically select a magnification ratio of 1:1 for the same size of paper as the original in the Auto Mode with the No. of Copies at “1” and  for the Image Quality.

NOTE: The Default Settings can be changed in the System Menu.

In the case where an optional cassette is present, the cassette selected in the System Menu can be changed. (Refer to appendix.)

The Image Quality Mode selected in the System Menu can be changed. (Refer to appendix.)

The Default Setting for the copy density can be changed to the `Auto`. (Refer to appendix.)

Auto Clear function

After the copy has been produced and a fixed interval (10 to 270 seconds) has elapsed, the copier will automatically revert to the state it was in when warm-up processing was completed. (However, the copy density mode and the Image Quality will not revert back to their original state. Copies can still be repeatedly produced with the same Copy Mode, No. of Copies, copy density and other settings if the Auto clear function has not been activated.

NOTE: Please refer to appendix. Please refer to appendix for information on changing the time interval before the Auto clear function activates.

Custom Sizes

Paper and original sizes that are not displayed on the Operation Panel can be registered as Custom Sizes. (Inputting Custom Size on page 2-9.)

Automatic Cassette Switching Function

If multiple cassettes contain the same size paper and the paper in one cassette runs out during copying, the automatic cassette switching function will switch paper feed from the empty cassette to the other cassette that still contains paper.

NOTE: An optional cassette is required to do this.

The Automatic Cassette Switching Function can also be turned off if not needed. (Refer to appendix.)

The paper has to be oriented in the same direction.

2 Preparations

Loading Paper

Paper can be loaded into either the cassette or the multi-purpose tray. Note for Adding Paper

After taking new paper out of its packaging, be sure to fan through the paper a few times to separate the sheets before loading that paper into the cassette or the multi-purpose tray.

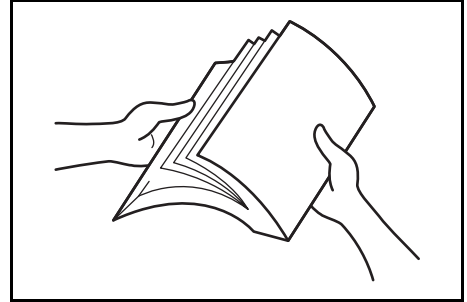

Set the paper in the cassette with the side which faced the top of its packaging facing up.

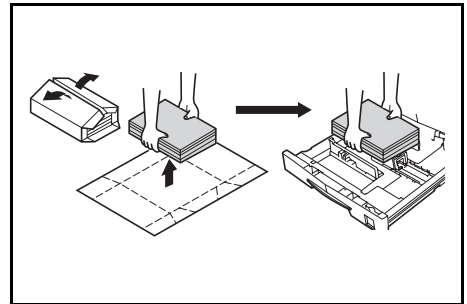

Important!

- When using paper that has been run through a machine before, check it to make sure that all staples and paper clips have been removed. Not doing so may result in poor images or malfunctions.
- Straighten out any creases or curls in the paper before loading it. Failure to straighten out creases and curls may lead to paper jams.
- Leaving paper out of its package under high temperature and high humidity conditions may lead to problems caused by ambient moisture. After loading paper into the cassette, store the remaining paper sealed in the paper storage bag. Also if any paper remains in the multi-purpose tray, store the paper sealed in the paper storage bag. Before leaving the machine in disuse for a prolonged period of time, remove the paper from the cassette and seal it in the paper storage bag to protect it from moisture.

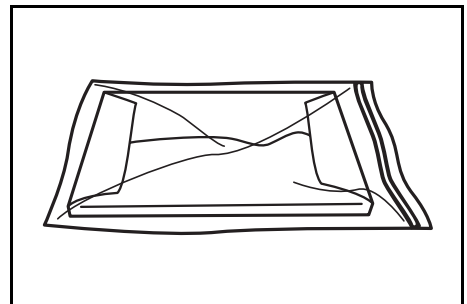

Loading Paper into the Cassette

Standard paper, recycled paper, and colored paper can be loaded into the cassette. Up to 300 sheets of standard paper (80 g/m²) or 100 sheets of thick paper (90 to 105 g/m²) can be set.

Paper sizes that can be loaded are: A3, B4, A4, A4R, B5, B5R, A5R, Folio, 11 × 17" (Ledger), 8 1/2 × 14" (Legal), 11 × 8 1/2", 8 1/2 × 11" (Letter), 5 1/2 × 8 1/2" (Statement), 8 1/2 × 13" (Oficio II), 8K, and 16K.

Note When loading paper into the cassette, set it with the side to be printed facing up.

- 1 Pull the cassette out toward you as far as it will go.

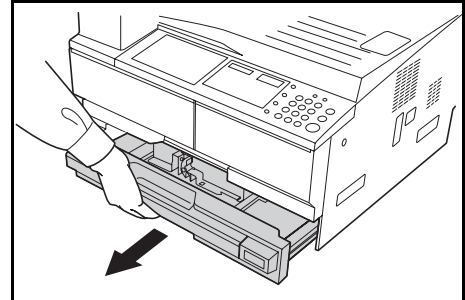

Note Do not pull more than one cassette out at a time.

- 2 Push down on the cassette base plate and secure it.

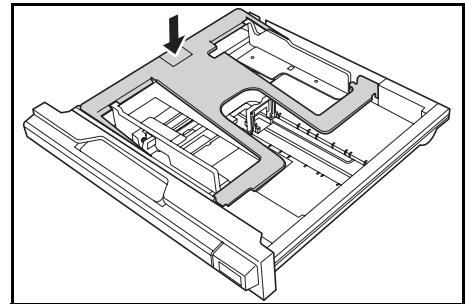

- 3 Grasp the paper width adjusting tab and adjust the width guides to the paper size.

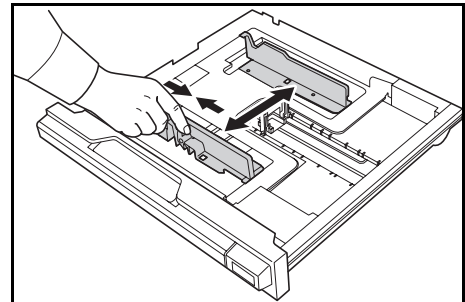

Important! Make sure that the width guides are flush against the paper. If there is space between the guides and the paper, set the width guides again.

Note The paper sizes are marked in the cassette.

- 4 Grasp the paper length adjusting tab and adjust the length guide to the paper size.

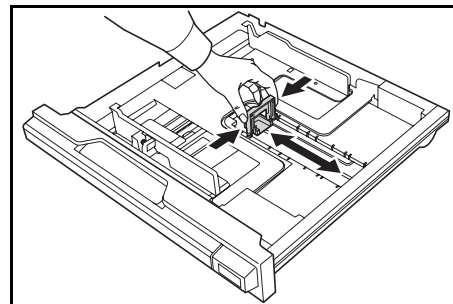
**Important!**

- Make sure that the length guide is flush against the paper. If there is space between the guide and the paper, set the length guide again.
- When setting 11 × 17" (Ledger) paper, move the paper length guide to the right end and push it down as shown in the illustration.

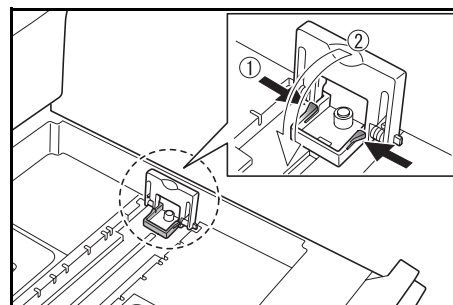

Note The paper sizes are impressed in the cassette.

- 5 Set the paper straight from the upper part.

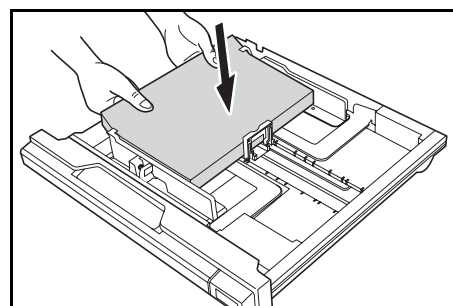
**Important!**

- Be careful not to bend or crease the paper when inserting it into the cassette. Creases in the paper may lead to paper jams.
- The maximum paper limit indicator **A** is provided on a paper width guide. Make sure that the paper loaded is below the maximum paper limit indicator.
- When loading paper into the cassette, set it with the side which faced the top of its packaging facing up.
- Be sure to adjust the width and length guides to the paper size before loading the paper. Failure to do so may result in paper skewing or jamming.
- If the length and width guides are not flush against the paper, a size that is different from the actual size may be displayed on the message display.
- When the paper has become wrinkled from moisture and cannot be fed, set the paper so that the wrinkled side is toward the length guide.

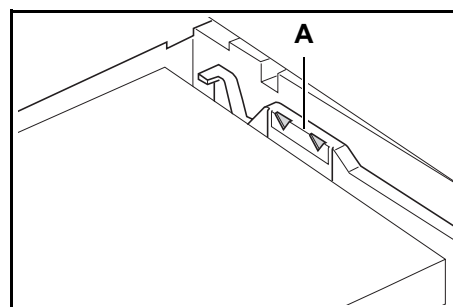

- 6 Affix the label supplied so that the paper size set in the cassette can be identified from the front of the cassette.

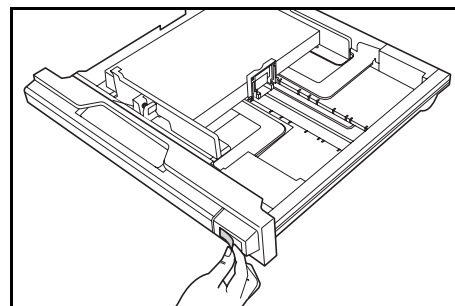

- 7 Gently push in the cassette.

Important! When the machine will not be used for a long period of time, remove the paper from the cassette, put it in a storage bag, and seal the bag in order to protect the paper from moisture.

Cassette Size Detection

Set the Size Detection on the operation panel to match the size of the paper loaded in the cassette. The copier has been set at the time of shipping for automatic detection in inch units for inch specifications, or in centimeter units (A-B columns) for metric specifications.

- 1 Press the **Paper Selection** key for 3 seconds.

The System Menu will be displayed.

- 2 Press \uparrow or \downarrow repeatedly until 19.Cassette1Size appears, and press the **OK** key.

When setting the size of the optional cassette (2 to 4), display 20.Cassette2Size, 21.Cassette3Size and 22.Cassette4Size.

System Menu:
19.Cassette1Size

- 3 Press \uparrow or \downarrow to select Auto Detect mm, AutoDetect inch, Oficio 2, 8K or 16K.

- 4 Press the **OK** key.

The display will blink and copying starts.

Setting Paper in the Multi Purpose Tray

In addition to standard paper and recycled paper, special paper can also be used. Be sure to set special paper in the multi purpose tray.

Up to 100 sheets of standard (80 g/m²) paper (25 sheets of A3, B4, Folio, 11 × 17" (Ledger), 8 1/2 × 14" (Legal), 8 1/2 × 13" (Oficio II), or 8K) can be set. The paper sizes that can be used are: Ledger R to Statement, A3 to B6R, A6R, Oficio 2, Cardstock, Folio R, 8K, 16K, 16KR, Executive, ISO B5, Envelope #10, Envelope #9, Monarch, Envelope #6.75, Envelope C5, Envelope C4, Envelope DL, OuhukuHagaki, Youkei 2gou and Youkei 4gou.

- Color paper: 100 sheets
- Hagaki: 15 sheets
- Thin paper and Thick paper (45 to 160 g/m²): 5 sheets up to 100 sheets (depending on paper size and thickness)

Important! • Envelope DL, Envelope C5, Envelope #10 (Commercial #10), Monarch, Youkei 4, Youkei 2: 5 sheets.

- 1 Open the multi-purpose tray.

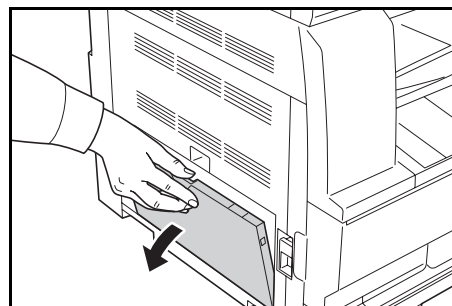

Note Pull out the multipurpose tray extension to match the paper size.

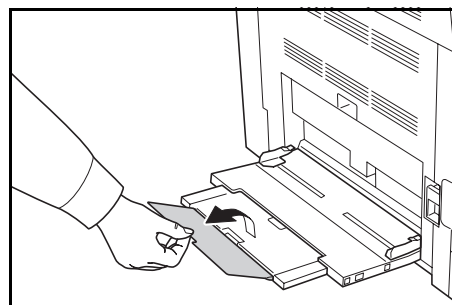
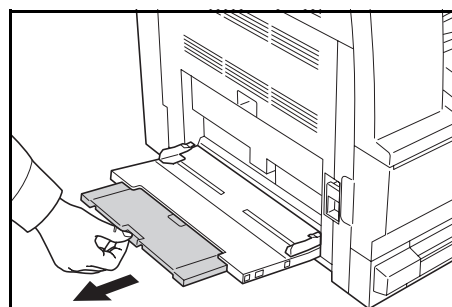

- 2 Adjust the sliders to the width of the paper to be set.

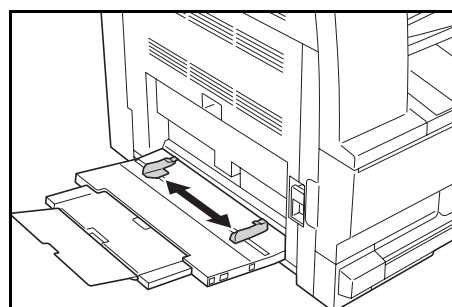

- 3 Set the paper along the sliders and put it in until it stops.

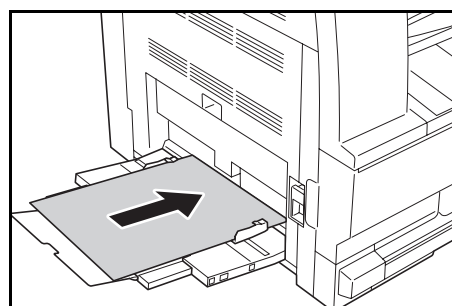

- Important!**
- Always straighten out postcards and other types of thick paper that are curled before using them. The paper may not be fed depending on the paper quality.
 - When loading paper into the multi-purpose tray, set it with the side which faced the top of its packaging facing down. If the front end of the paper is curled, straighten it out before setting it.
 - Make sure there are no creases, etc. in the paper. Creases in the paper may lead to paper jams.
 - Make sure that the slider is flush against the edge of paper. If not, adjust the slider until it is flush with the edge of paper.

Note When loading paper into the multi-purpose tray, set it with the side to be printed facing down.

Loading postcards or envelopes in the MP tray

- 1 When loading a postcard or envelope, open the paper stopper shown in the figure.

For landscape envelopes, close the flap. Insert the envelope all the way along the width guides, keeping the printing side face-down and the edge with the flap facing towards you.

For portrait envelopes, close the flap. Insert the envelope all the way along the width guides, keeping the printing side face-down and the edge with the flap facing the slot.

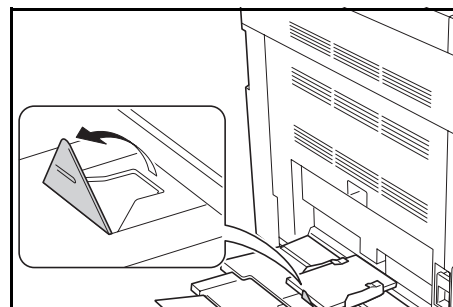

Up to five envelopes can be loaded.

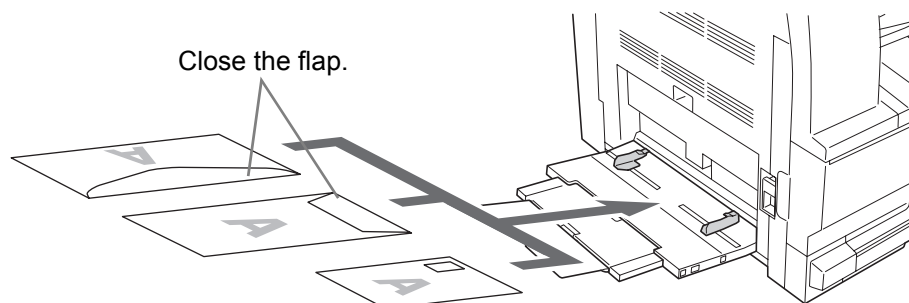

Important!

How to load envelopes (orientation and facing) will differ depending on the type of envelope. Be sure to load it correctly, otherwise printing may be done in the wrong direction or on the wrong face.

MP Tray Size and Media Type

Adjust the paper in the MP Tray, register the paper size using the Operation Panel and specify the media type.

Selecting a Size from Regular Sizes

- 1 Press the **Paper Selection** key for 3 seconds.
- 2 The System Menu will be displayed.
Press \uparrow or \downarrow repeatedly until 23.MPTray Config appears, and press the **OK** key.
In the case of the selection of Other Standards or Custom Size, proceed to Inputting Other Standards on page 2-9 or Entering Custom Size on page 2-9.

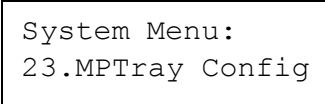

System Menu:
23.MPTray Config

Important! Use the illustration as a reference when setting the paper in the ## R in the MP Tray.

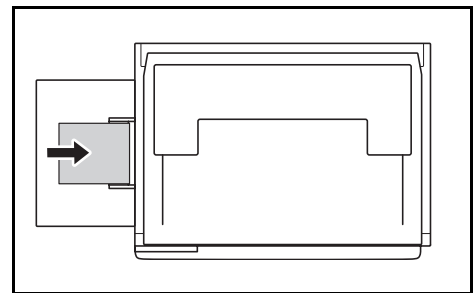

- 3 Press \uparrow or \downarrow to select the paper size, and press the **OK** key.
- 4 Press \uparrow or \downarrow to select the media type, and press the **OK** key.
The display will blink and the copier will return to the System menu.
- 5 Press \uparrow or \downarrow to select 00.Setting done, and press the **OK** key.
The display will blink and copying starts.

Selecting a Size from Other Regular Sizes

- 1 Select the Other Standards. (Refer to Selecting a Size from Regular Sizes on page 2-7.), and press the **OK** key.
- 2 Press \uparrow or \downarrow select the paper size, and press the **OK** key.
The paper size displayed are as shown below.
Inch specifications:
A3 R, A4 R, A4, A5 R, A6 R, B4 R, B5 R, B5, B6 R, Folio R, Oficio 2, Executive, ISO B5, Envelope #10, Envelope #9, Monarch, Envelope #6.75, Envelope C5, Envelope C4, Envelope DL, Hagaki, OufukuHagaki, Youkei 2gou, Youkei 4gou, 8k R, 16k R, 16k
Metric specifications:
A6 R, B5, B6 R, Ledger R, Legal R, Letter R, Letter, Statement R, Oficio 2, Executive, ISO B5, Envelope #10, Envelope #9, Monarch, Envelope #6.75, Envelope C5, Envelope C4, Envelope DL, Hagaki, OufukuHagaki, Youkei 2gou, Youkei 4gou, 8k R, 16k R, 16k
- 3 Proceed to Step 4 of Selecting a Size from Regular Sizes on page 2-7.

Specifying Custom Paper Size

- 1 Select the **Customized Size**. (Refer to **Selecting a Size from Regular Sizes** on page 2-7.), and press the **OK** key.
- 2 Press **↑** or **↓** to enter the Length Size. 3.88 to 11.63(")/98 to 297(mm): The range in which setting is possible, and press the **OK** key.

Non-std size L
297mm
- 3 Press **↑** or **↓** to enter the Width Size. 5.88 to 17.00(")/148 to 432(mm): The range in which setting is possible, and press the **OK** key.

Non-std size W
148mm
- 4 Proceed to Step 4 of **Selecting a Size from Regular Sizes** on page 2-7.

Selecting Special Paper Type

Select the media type when copying on special types of paper such as thick paper (1) and vellum paper (2). When the media type has been selected, the copier will change the fixing temperature to match the paper.

- 1 Press the **Media Type** key and select the media type.
The indicator for the media type selected will light up.
- 2 Proceed with the copying operation.
When media type has been selected, the copying speed is reduced.

Loading Originals

Follow the steps below to load originals for copying or sending.

Placing Originals on the Platen

You may place books or magazines on the platen in addition to ordinary sheet originals. In addition, when copying from an original which cannot be set in the document processor, open the document processor and set the original directly on the platen.

- 1 Open the original cover.

Note If the optional document processor is installed, open the document processor. Before opening the document processor, be sure that there are no originals left on the original table or on the original eject table. Originals left on the original table or on the original eject table may fall off when the document processor is opened.

- 2 Keep the document processor open if the original is 40 mm or thicker.

Place the original. Put the scanning side facedown and align it flush against the original size indicator plates with the back left corner as the reference point.

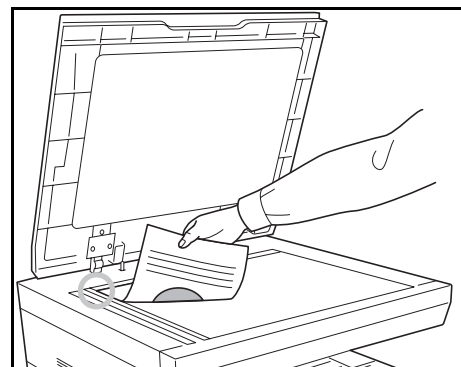

- 3 Close the original cover.

Important! Do not push the original cover forcefully when you close it. Excessive pressure may crack the platen glass.

Note Shadows may be produced around the edges and in the middle of open-faced originals.

Caution Do not leave the document processor open as there is a danger of personal injury.

Loading Originals in the Document Processor

The optional document processor automatically scans each sheet of multiple originals. Both sides of two-sided originals are scanned.

Originals Supported by the Document Processor

The document processor supports the following types of originals.

- Sheet originals only
- Paper weight
 - One-sided originals: 45 g/m² to 160 g/m²
 - Two-sided originals: 50 g/m² to 120 g/m²
- Sizes: A3 to A5R, Folio, 11 × 17" (Ledger) to 5 1/2 × 8 1/2" (Statement)
- Number of originals: 50 sheets (50 g/m² to 80 g/m²) (30 sheets for auto selection mode)

Originals Not Supported by the Document Processor

Do not use the document processor for the following types of originals.

- Soft originals such as vinyl sheets
- Transparencies such as OHP film
- Carbon paper
- Originals with very slippery surfaces
- Originals with adhesive tape or glue
- Wet originals
- Originals with correction fluid which is not dried
- Irregularly shaped (non-rectangular) originals
- Originals with cut-out sections
- Crumpled paper
- Originals with folds (Straighten the folds before loading. Failure to do so may cause the originals to jam).
- Originals bound with clips or staples (Remove the clips or staples and straighten curls, wrinkles or creases before loading. Failure to do so may cause the originals to jam).

Part Names of the Document Processor

- 1Original table
- 2Original insert guides
- 3Left cover
- 4Original eject table
- 5Ejection extension
- 6Document processor release grip
- 7Ejection tray

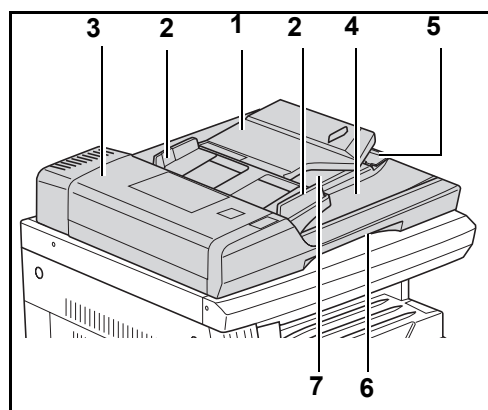

How to Load Originals

Before loading originals, be sure that there are no originals left on the original eject table. Originals left on the original eject table may cause the new originals to jam.

- 1 Adjust the original width guides to fit the originals.

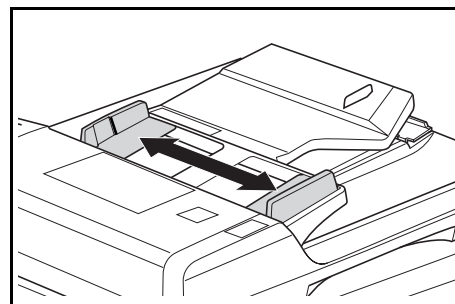

Note Before setting originals, make sure that there are no originals remaining on the original eject table. Originals left on the eject table may cause other originals to jam. When setting multiple originals at one time, be sure to use originals of the same size. It is, possible, however to use different size originals of the same width (for example, 11 x 17" (Ledger) and 11 x 8 1/2" or A4 and A3 at the same time in the auto selection mode. Refer to Chapter 4 Auto Selection Mode.)

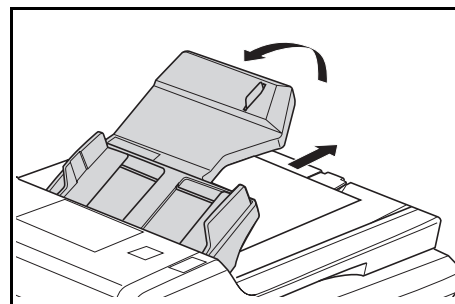

- 2 Arrange the originals in order and set them face up (front side up for 2-sided originals) on the original table.

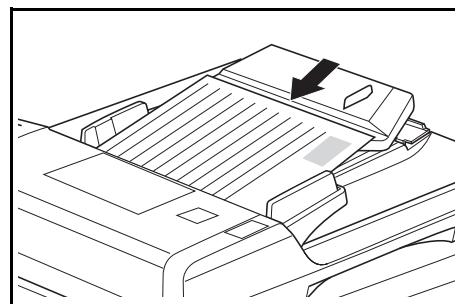

Important! Be sure to set only a number of originals that does not exceed the level indicator located inside the rear original insert guide. If you set originals exceeding the specified number, the originals may jam.

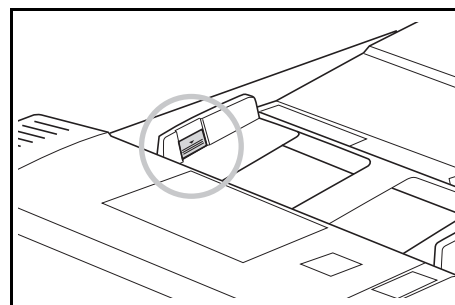

To keep ejected originals from falling off the machine, open the ejection extension when using large originals such as A3, B4, 11 × 17" (Ledger), and 8 1/2 × 14" (Legal).

When copying from 2-sided originals, the originals are temporarily ejected onto the ejection tray in order to turn them over. Do not touch them at this point. Any attempt to remove them may cause the originals to jam

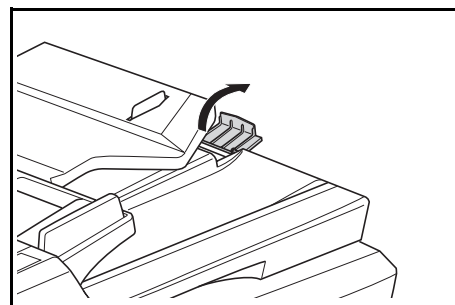

Turning Power On

To turn machine power on:

- 1 Open the main power switch cover located on the right side of the machine and turn the main power switch on (I). The machine starts to warm up.

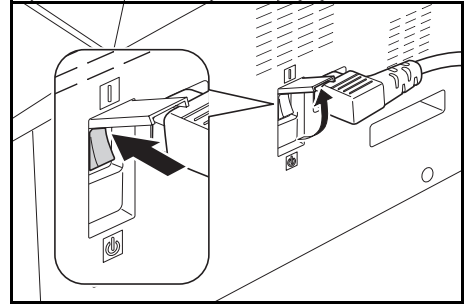

- 2 Once warm-up is completed, the **Start** indicator lights up green.

User Interface language

You can select the language that is used in the message display.

- 1 Display the System Menu.
- 2 Press the \uparrow key or the \downarrow key to select 02 .Language. Press the **OK** key.
- 3 Press the \uparrow key or the \downarrow key to select the language. Press the **OK** key.

3 Basic Operation

This chapter explains the following operations.

- Basic Copying Procedure
- Zoom Copying
- Duplex Copying
- Collated Copying
- Combined Copying
- Interrupt Copying
- Low Power Mode
- Auto Sleep

Basic Copying Procedure

- 1 Turn the main power switch on (|). At the end of warm-up, the **Start** indicator lights up green.

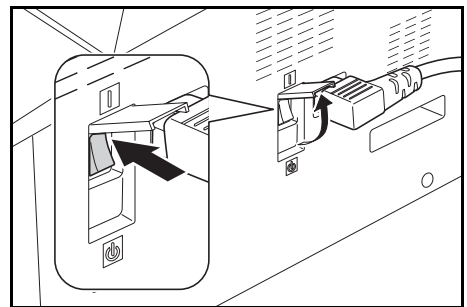

- 2 Set the original onto the platen. Be sure to set the original by aligning it with the left rear corner of the platen along the original size indicator plates.

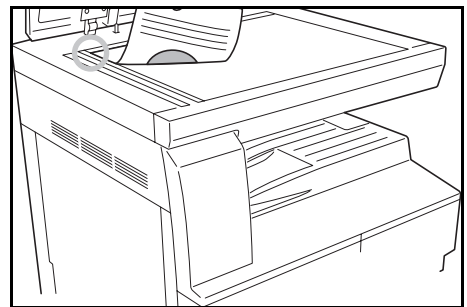

Note For the method of setting originals in the optional document processor, see **Loading Originals in the Document Processor** on page 2-11.

- 3 Select the paper size. If **Auto** is lit on the message display, the paper of the same size as the original is automatically selected.

To change the paper size, press the **Paper Select** key to select the desired paper source.

- 4 Press the image quality Selection key to light up the image quality mode indicator.
See the table below for image quality to choose.

Image quality mode	Description
Text + Photo	Select to copy originals that contain a mixture of both text and photographs.
Text	Select to copy originals that contain large amounts of text, such as documents, etc.
Photo	Select to copy originals that contain photographs.

- 5 Adjust the copy density either manually (manual density mode) or automatically (auto density mode) with automatic detection of the contrast of the original.
- 6 Press the numeric keys to set the desired number of copies (Up to 999).
- 7 Press the Start key to start copying.
- 8 Finished copies are delivered into the output tray.

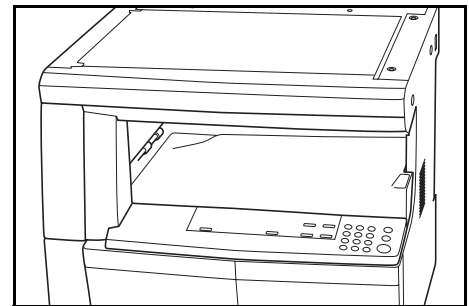

Note The capacity of the output tray is 250 sheets of standard paper (80 g/m²). The capacity varies depending of the paper that is used.

! Caution

If the machine will not be used for a short period of time (overnight, etc.), turn the main power switch off (○). If it will not be used for an extended period of time (vacations, etc.), remove the power plug from the outlet for safety purposes during the time the machine is not in use.

A diagram illustrating the power switch and power plug. On the left, a power switch is shown with a black arrow pointing to it. On the right, a power plug is shown being pulled out of a wall outlet.

Zoom Copying

Copied images can be reduced or enlarged by zooming. The following modes are available for zoom copying.

Mode	Description
Auto zoom ratio selection mode	Original images are reduced or enlarged according to the selected paper size.
Zoom mode	The zoom ratio can be changed from 25 % to 400 % in 1 % increments.
Preset zoom mode	A preset zoom ratio can be set to reduce or enlarge original images: 100%, Auto, 400% (Max.), 200 % (A5 → A3), 141 % (A4 → A3, A5→A4), 127 % (Folio → A3), 106 % (11 × 15" → A3), 90 % (Folio → A4), 75 % (11 × 15" → A4), 70 % (A3 → A4, A4 → A5), 50 %, 25% (Min.)

Note When the magnification ratio is larger than 201%, the images will be rotated 90° counter-clockwise prior to copying.

Auto Zoom

The original image is reduced or enlarged according to the selected paper size.

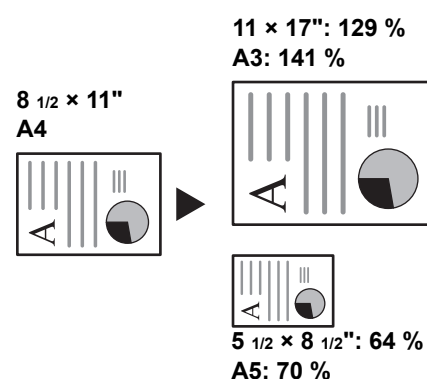

- 1 Set the original.
- 2 Press the **Auto%/100%** key. `Auto %` Indicator lights on the message display.
- 3 Press the **Paper Selection** key to select the copy paper. The zoom ratio is displayed on the message display.
- 4 Press the **Start** key. Copying starts.

Manual Zoom

The zoom ratio can be manually set between 25 % and 400 % in 1 % increments.

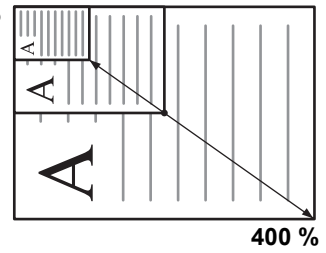

- 1 Set the original.
- 2 Press the \uparrow key or the \downarrow key. The zoom ratio will be displayed in the No. of Copies display.
- 3 Press the OK key to confirm the zoom ratio.
- 4 Press the **Start** key. Copying starts.

Duplex Copying

Duplex (two-sided) copies can be made from a variety of originals including double-page spread or two-sided originals.

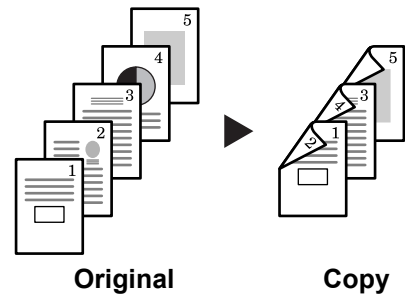

Note The optional duplex unit must be installed.

The following modes are available for duplex copying:

Mode	Description
1-sided->2-sided (2-sided copying from 1-sided originals)	One-sided originals are copied onto the front and back sides of the copy paper. If the number of originals is odd, the back side of the last copy page is blank.

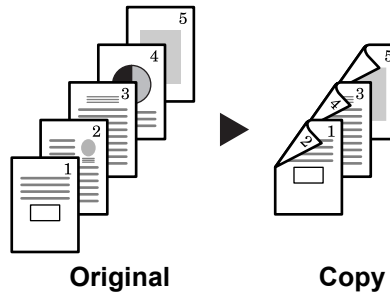

Note

In the 1-sided to 2-sided mode, select the following setting.

- Binding at left/right of originals → Binding at left of copies: The images for the back side are copied without rotation...**A**
- Binding at left/right of originals → Binding at top of copies: The images for the back side are rotated 180 degrees and copied. Finished copies can be bound at the top so that double-page spread pages are copied in the same orientation...**B**

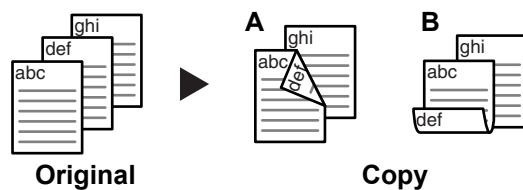

Mode	Description
2 sided->2 sided (2-sided copying from 2-sided originals)	Front and back sides of originals are copied in the same way onto both sides of copy paper.

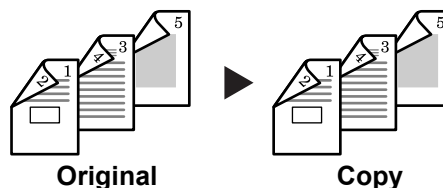

Note
 The paper sizes that can be used are A3 to A5R, Folio, 11 × 17" (Ledger), 8 1/2 × 14" (Legal), 8 1/2 × 11" (Letter), 11 × 8 1/2", 5 1/2 × 8 1/2" (Statement), 8 1/2 × 13" (Oficio II), 8K, 16K, and 16KR.

Book->2-sided (2-sided copying from double-page spread originals)	A double-page spread original of magazines, books, etc. can be copied onto both sides of copy paper by pressing the Start key one time.
---	--



Note
 The original sizes that can be used are A3, B4, A4R, B5R, A5R, 11 × 17" (Ledger), 8 1/2 × 11" (Letter), and 8K. The paper sizes are limited to 11 × 8 1/2" and 16K in the inch specifications and A4, B5, and 16K in the metric specifications. The paper size can be changed and the zoom ratio adjusted to fit the size of the paper.

- 1 Set the original.
- 2 Press [2-sided], select the type of original and select $\text{[1]} \rightarrow \text{[2]}$, $\text{[2]} \rightarrow \text{[2]}$ or $\text{[book]} \rightarrow \text{[2]}$ to light up the corresponding display.
- 3 Enter the number of copies using numeric keys.
- 4 Press the **Start** key. Scanning of the original starts.
 If the originals have been set in the optional document processor, copying starts automatically.
 If the original has been set on the platen, a message prompting replacement of the original is displayed. In this case, proceed to the next step.
- 5 Replace the original and press the **Start** key. Scanning of the original starts.
- 6 If no original remains, press the **Enter** key. Copying starts.

2-Sided Copy Reverse Side Rotation Setting

Follow the procedure below to change the rotation setting for the reverse side when making 2-Sided copies.

- 1 Press the **2-sided** key for 3 seconds.

42.Duplex 2nd Rotation On

- 2 The System Menu for the reverse side setting of 2-Sided Copies will be displayed.

Press \uparrow or \downarrow to select `Rotation On` in the case where the reverse side is to be rotated or `Rotation Off` when it isn't to be rotated, and then press the **OK** key.

The display will blink and the copier will return to the state where copying can be continued.

Split Copying

Copy books, magazines, etc. with two facing pages of an open-faced original onto separate sheets of paper.

Two-sided to One-sided

Copies each side of a two-sided original onto two individual sheets. The optional document processor is required.

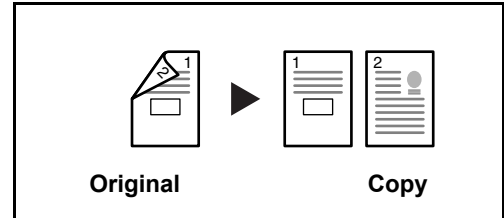



Book to One-sided

Produces a 1-sided copy of a 2-sided or open book original.

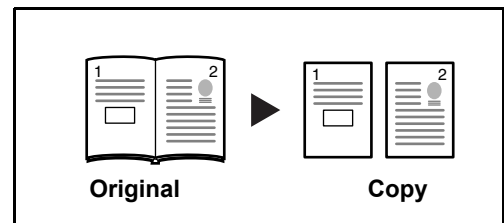
The procedure for using two-sided/duplex copying is explained below.



- 1 Place the originals on the platen.
- 2 Press **[Split]**, select the type of original, and select  or  to light up the corresponding display.
- 3 Press **Start** to start scanning.
If the originals have been set in the optional document processor, copying starts automatically.
If the original has been set on the platen, a message prompting replacement of the original is displayed. In this case, proceed to the next step.
- 4 Replace the original and press the **Start** key. Scanning of the original is performed.
- 5 After scanning all originals, press the **OK** key to start copying.

Collated Copying

A number of collated copy sets can be produced.

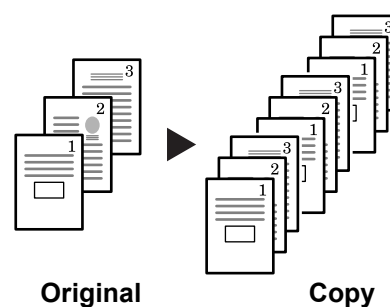





Note If the optional document processor is installed, you can select whether or not to turn on the sort mode at a default setting.

- 1** Set the original.
- 2** Press the **Collate** key.
- 3** Input the number of copies and press the **Start** key. Scanning of the original starts.
If the originals have been set in the optional document processor, copying starts automatically.
If the original has been set on the platen, a message prompting replacement of the original is displayed. In this case, proceed to the next step.
- 4** Replace the original and press the **Start** key. Scanning of the original starts.
- 5** If no original remains, press the **OK** key. Copying starts.

Combined Copying

Two or four originals are reduced and copied onto a single sheet. Also, borderlines of each original can be marked with solid or dotted lines.

Press the Combine key to light up the  →  or  →  indicator.

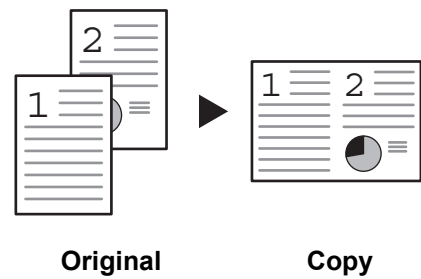

Note Both the original size and the copy paper size must be standard size.

The following modes are available for combine copying.

Mode	Description
------	-------------

Use this mode to copy two originals onto one sheet.

2-in-1

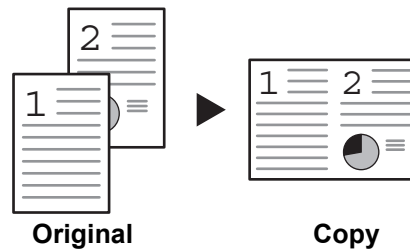

Use this mode to copy four originals onto one sheet.

4-in-1
(horizontal)

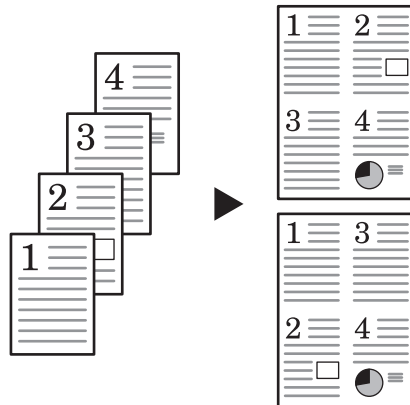

4-in-1
(vertical)

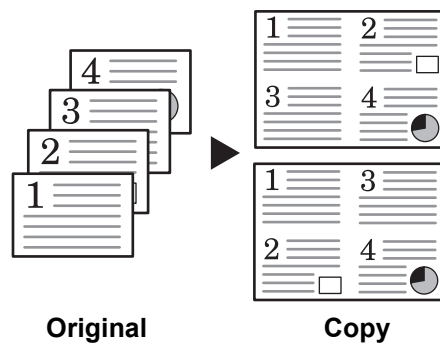

2-in-1

The orientations of the originals and the finished copy are shown below.

Using the platen:

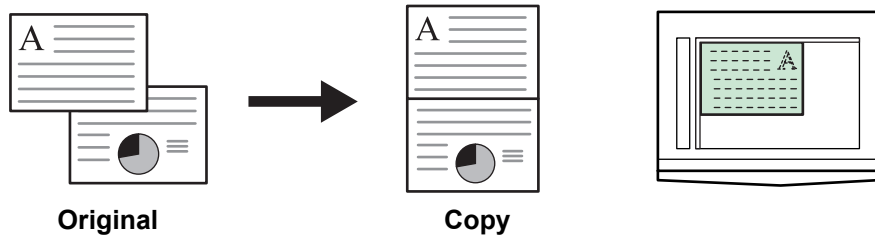
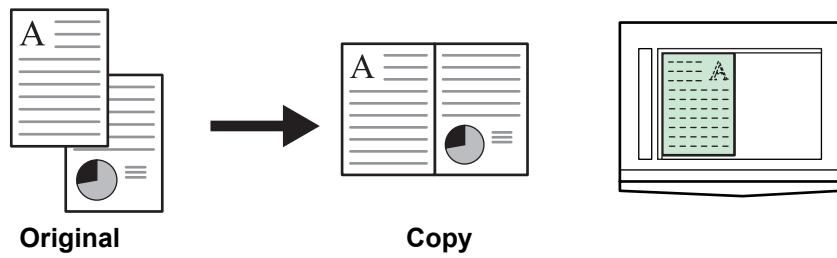

Using the document processor:

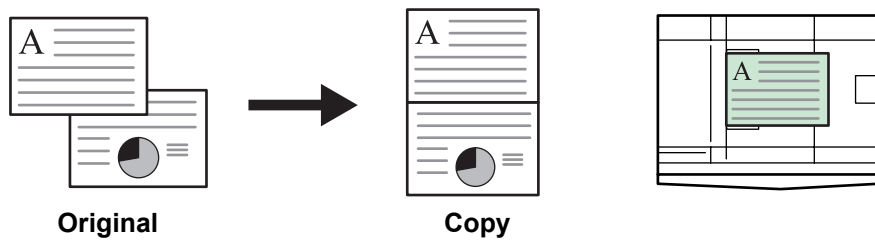
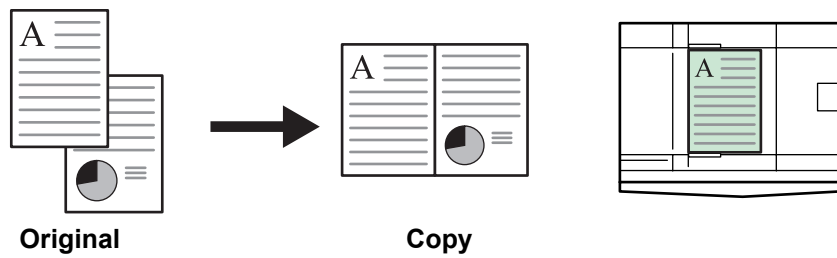

4-in-1 (horizontal)

The orientations of the originals and the finished copy are shown below.

Using the platen:

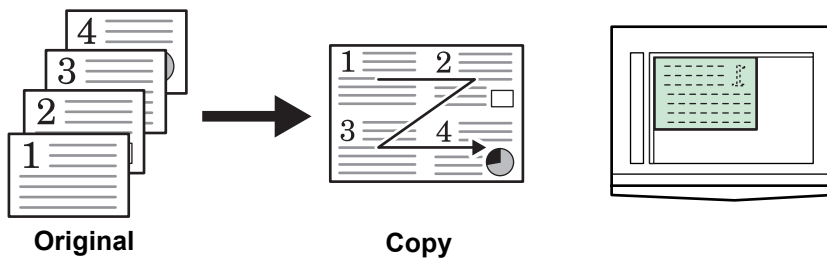
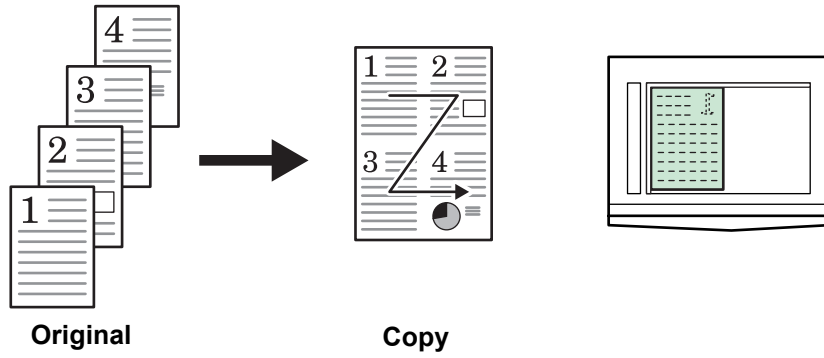

Using the document processor:

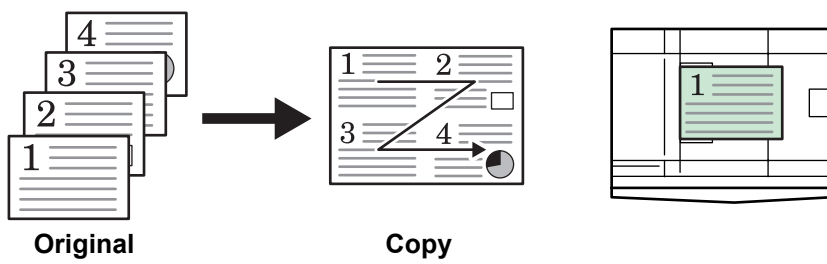
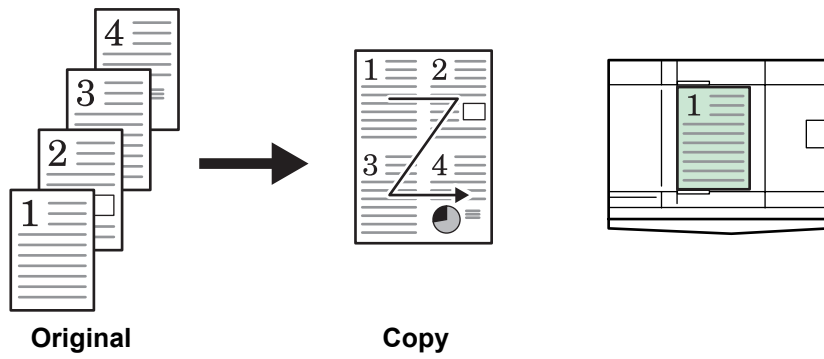

4-in-1 (vertical)

The orientations of the originals and the finished copy are shown below.

Using the platen:

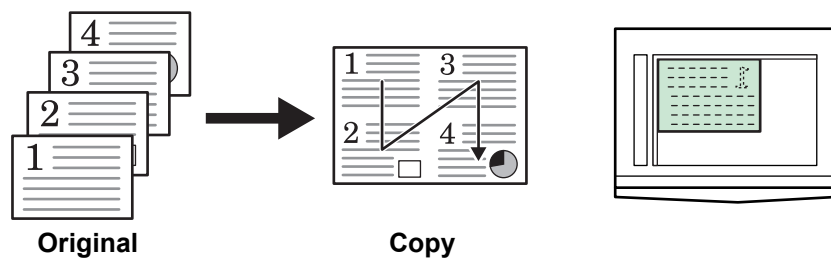
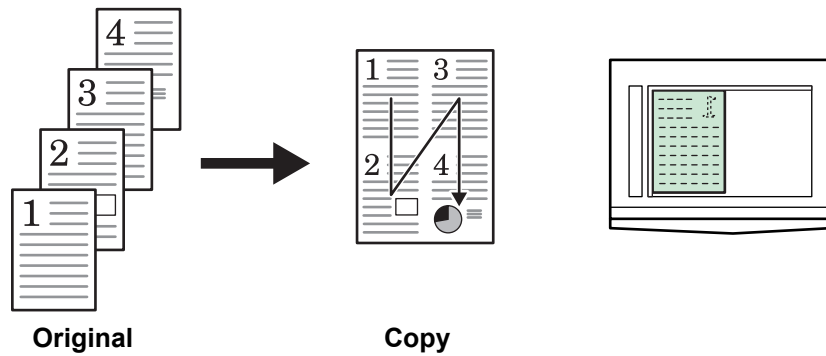

Using the document processor:

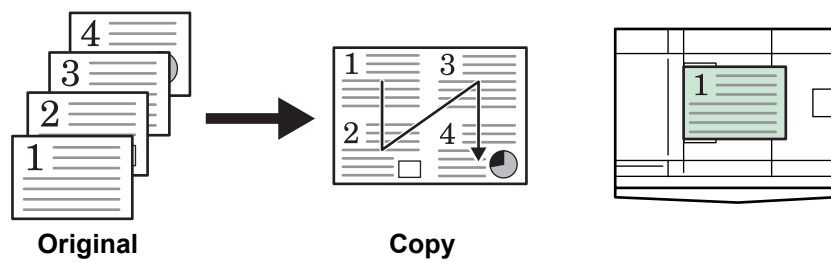
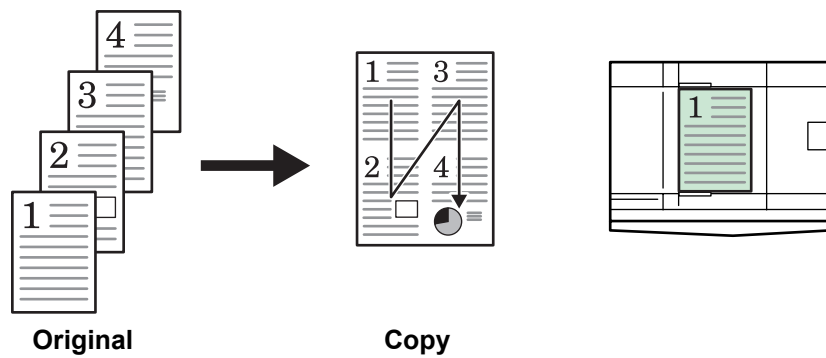

Interrupt Copying

The interrupt mode temporarily stops the output of copy jobs and allows the output of an urgent copy. After the urgent interrupt job is finished, the interrupted job will be automatically resumed.

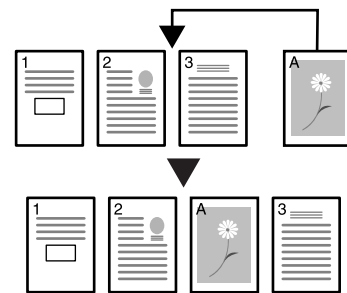

- 1** During a copy job press the **Interrupt** key.
The Interrupt indicator will blink
- 2** Remove the originals of the ongoing copy job.
- 3** Set the original for interrupt copying and perform copying.
- 4** After the interrupt copying is complete, press the **Interrupt** key. The settings for the interrupted job are restored.
- 5** Replace the original with the originals that have been stored. Press the **Start** key to resume copying.

Low Power Mode

Pressing the **Energy Saver** key puts the machine into a resting state (low power mode) even when the main power switch is on. During low power mode, the No. of Copies/Zoom display shows '---'.

Press the any key to resume copying operations. The recovery time before copies can be made is 10 seconds.

Note The machine also recovers from low power mode when the original cover is opened, or an original is loaded in the optional document processor.

This machine is equipped with the auto low power function that automatically puts this machine into the lower power mode if no operation has been performed on the machine for a preset period of time. The factory default setting time is one minutes.

Auto Sleep

This machine is equipped with the auto sleep function that automatically puts this machine into the sleep mode if no operation has been performed on the machine for a preset period of time. The factory default setting time is one minute.

Press the Energy Saver key again to resume copying operations. The recovery time 17.2 seconds.

Copiers and printers are generally in a standby mode more than they are in actual operation, so power consumption in the standby mode occupies a large part of overall consumption.

Automatically putting the machine in a resting state reduces unnecessary power consumption in the standby mode, resulting in a lower electricity bill.

4 Job Accounting

Overview of Job Accounting

Job Accounting allows you to manage the number of copies for each department through the setting of the Department ID Code separately for each department.

This copier has the following features available through the Department ID Code.

- A maximum of 100 Sections can be managed.
- ID Codes can be set from 0 to 99999999 for a maximum of 8 digits.
- The accumulated totals of pages copied according to ID Code can be printed out on paper.

The factory default setting is indicated by an asterisk (*).

Job Accounting	Description	Available settings	Reference Page
01.JobAccounting	In order to carry out Job Accounting, set this to on (set), Set this to oFF (no setting) when Department Management is not needed.	On: Set Off: No Setting*	4-4
02.Register code	Registers the Department ID Code to be used. Up to 100 sections can be registered as Department ID Codes.		4-2
03.Delete code	Deletes Department ID Codes that will not be used anymore.	Yes: Delete No: No Deletion	4-3
04.Count Clear	Batch-clears the copy count after a set amount of copies have been managed. The counts cannot be deleted separately in accordance with the Department ID Codes.		4-3
05.Print list	Outputs the number of copies produced by Department in a report format.		4-3

Job Accounting Operation Procedures

Follow the procedures listed below to operate Job Accounting.

- 1 Press the Exposure Adjustment keys on both sides for 3 seconds while pressing the **Logout** key.

Job Accounting: will be displayed.

- 2 Press \uparrow or \downarrow to select each of the mode displays.

NOTE: Refer to each of the following setting procedures and make the settings. Each of the Modes can be selected by pressing the numeric keys.

- 3 After completing each setting, press \uparrow or \downarrow to select 00.Set Completed, and then press the **OK** key.

Job Accounting: 00.Set Completed

Department ID Code Registration

A Department ID Code of up to 8 digits can be entered.

- 1 Display Job Accounting. (Refer to *Job Accounting Operation Procedures on page -2.*)

- 2 Press \uparrow or \downarrow to select display 02.Register code, and then press the **OK** key.

Job Accounting: 02.Register code

- 3 Enter the Department ID Code to be registered (up to a maximum of 8 digits) using numeric keys.

NOTE: Number from 0 to 99999999 can be entered.

If a mistake is made during input it can be cleared by pressing the **Stop/Clear** key and the value reentered.

- 4 Press the **OK** key.

The code that was input will flash on and off.

- 5 After confirming the code that was entered, press the **OK** key.

The display will return to that of Step 2.

NOTE: If an existing Department ID Code is attempted to be registered, an error will occur and Already registered. will display in the message display. In this case, register a different Department ID Code.

Deleting Department ID Codes

Deleting a registered Department ID Code.

- 1 Display Job Accounting. (Refer to *Job Accounting Operation Procedures on page -2.*)
- 2 Press \uparrow or \downarrow to select display 03.Delete code, and then press the **OK** key.
- 3 Enter the Department ID Code to be deleted using the numeric keys.

Job Accounting:
 03.Delete code

NOTE: If a mistake is made during input it can be cleared by pressing the Stop/Clear key and the value reentered.

- 4 Confirm the code to be deleted, and then press the **OK** key.
- 5 Press \uparrow or \downarrow to select Yes, and then press the **OK** key.

The display will return to that of Step 2.

Clearing the Job Accounting Count

The Total No. of Copies Count for all departments can be cleared.

- 1 Display Job Accounting. (Refer to *Job Accounting Operation Procedures on page -2.*)
- 2 Press \uparrow or \downarrow to select display 04.Count Clear, and then press the **OK** key.
- 3 Press \uparrow or \downarrow to select Yes, and then press the **OK** key.

Job Accounting:
 04.Count Clear

The display will return to that of Step 2.

Printing the Job Accounting List

The Total No. of Copies by department can be printed.

NOTE: Check to make sure that Letter/A4 size paper is loaded in the cassette.

- 1 Display Job Accounting. (Refer to *Job Accounting Operation Procedures on page -2.*)
- 2 Press \uparrow or \downarrow to select display 05.Print list, and then press the **OK** key.
- 3 Press \uparrow to select Yes, and then press the **OK** key.

Job Accounting:
 05.Print list

The list will be printed and the display will return to that of Step 2.

How to set Job Accounting

Set Job Accounting to enable or disable it.

- 1 Display Job Accounting. (Refer to *Job Accounting Operation Procedures* on page -2.)
- 2 Press \uparrow or \downarrow to select display
01.JobAccounting, and then press the **OK** key.
- 3 Press \uparrow or \downarrow to select **On** when Job Accounting is to be used and **Off** when it will not be used, and then press the **OK** key.

Job Accounting: 01.JobAccounting

The display will return to that of Step 2.

Making copies in Job Accounting Mode

When Job Accounting is being carried out "=" = =" will be displayed in the No. of Copies display and copy operations can be carried out by entering the assigned Department ID Codes using the numeric keys.

IMPORTANT: Always remember to press the **Logout** key after completing copying.

- 1 Confirm the ID code to be deleted and then press the **OK** key.
"1" will be displayed on the No. of Copies display.

NOTE: When an error has been made in input, press **[Stop/Clear]** and input the data again.

When the Department ID Code that is input does not match any of the Department ID Codes registered, *Illegal Account.* is displayed and the copier returns to the "=" = =" display. Input the correct Department ID Code.

- 2 Carry out regular copy operations.
- 3 Press the **Logout** key after completing copying.
"=" = =" will be displayed on the No. of Copies display.

5 Optional Equipment

The following options are available for this machine.

- Document Processor
- Paper Feeder
- Duplex Unit
- Key Counter
- Printer Kit / Printer Server
- Additional Memory

Document Processor

This equipment automatically feeds and scans multiple-sheet originals one by one. Two-sided originals are automatically turned over so that both sides can be scanned.

Important! When moving this machine, be sure to close the document processor.

Paper Feeder

In addition to the cassette(s) provided with the main body, a paper feeder (with cassettes that can hold 300 sheets each) can be used.

- The number of sheets that can be accommodated: 300 sheets (standard paper, 64 to 105 g/m²).
- Paper sizes that can be set are: A3, B4, A4, A4R, B5, B5R, A5R, Folio, 11 × 17" (Ledger), 8 1/2 × 14" (Legal), 11 × 8 1/2", 8 1/2 × 11" (Letter), 5 1/2 × 8 1/2" (Statement), 8 1/2 × 13" (Oficio II), 8K, and 16K

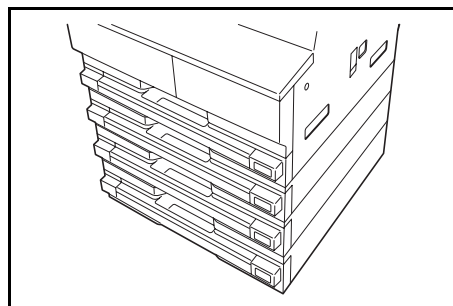

Copy paper can be set in the same way as the standard cassette provided with the main body. (See page 2-1.)

The left covers are provided to allow paper to be removed when a paper jam occurs.

Important! When lifting and transporting this machine, be sure to detach the paper feeder in advance.

Note Up to three cassettes can be added.

Duplex Unit

Two-sided copies can be made if the duplex unit is installed. Two-sided copies of sizes from A3 to A5R, Folio, 11 × 17" (Ledger) to 5 1/2 × 8 1/2" (Statement), 8K, 16K, and 16KR (64 to 80 g/m²) can be made.

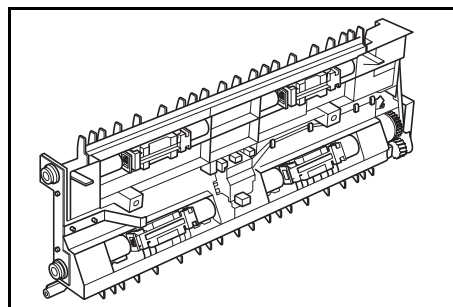

Key Counter

The key counter is used to confirm the amount of usage of the copier functions. It is useful in managing copier usage for each department, section, etc. as well as in the company overall.

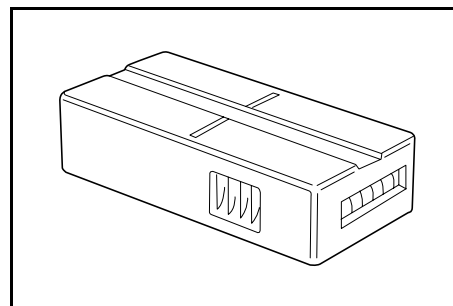

Setting the Key Counter

Set the key counter securely in the key counter slot.

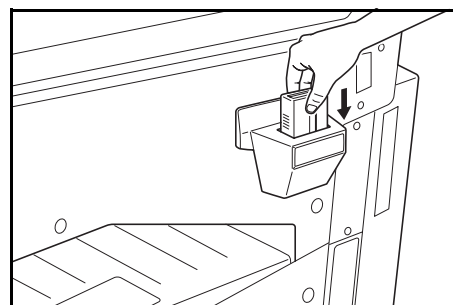

Note In the case where the key counter is used, no one will be able to make copies until it is installed in the machine. *Insert key counter* will be displayed when the key counter has not been securely inserted.

Printer Kit / Printer Server

A printer kit can be installed to use the copier as a printer as well. Ask your local dealer for more information. In some countries a printer server is available as well.

Additional Memory

A memory can be added for the copier functions and the printer functions respectively. Adding a memory will increase the maximum number of originals that can be scanned at one time. Also complicated data can be printed. An additional memory of 64 MB or 128 MB is effective for originals containing photos with a low compression ratio.

- Notes**
- Available memory
For copier: 16 MB, 32 MB, 64 MB, 128 MB
 - Number of originals that can be scanned (A4 originals with of 6 % coverage, **Text + Photo** mode)

16 MB	32 MB	64 MB	128 MB
289 sheets	392 sheets	597 sheets	1006 sheets

Optional Equipment

Overview of Optional Equipment

The following optional equipment is available for the machine.

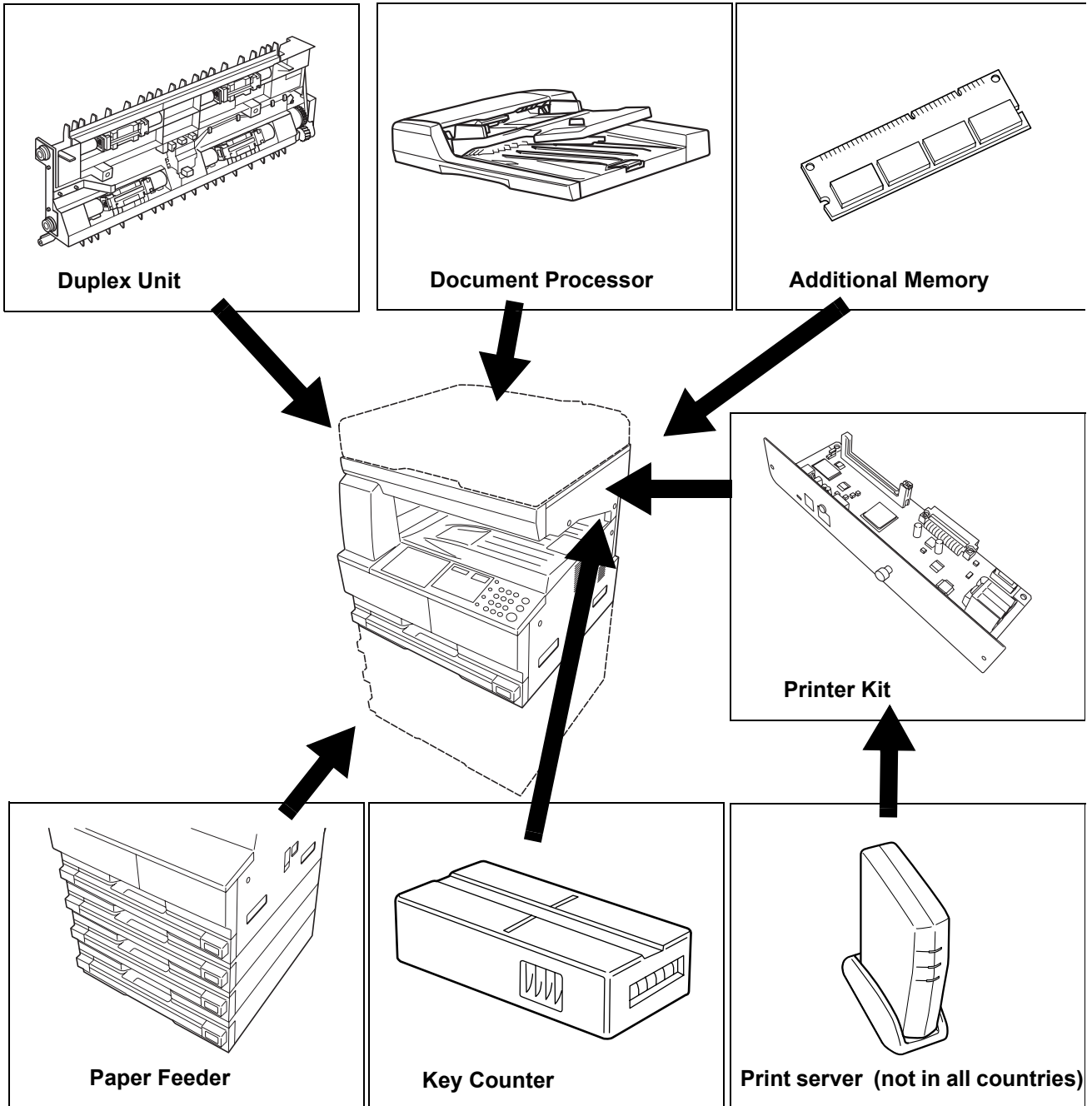

6 Maintenance

Cleaning the Machine



Caution

For safety purposes, always remove the power plug from the outlet when performing cleaning operations.

Cleaning the Original Cover

Open the original cover and wipe the back side of the cover with a soft cloth dampened with alcohol or mild neutral detergent.

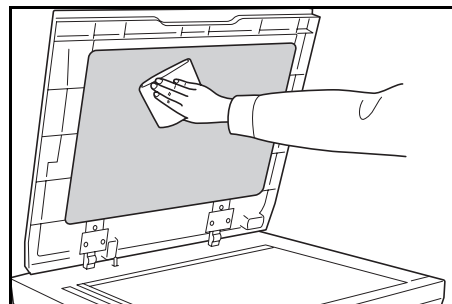

Important! Never use thinner or other organic solvents.

Cleaning the Platen

Open the original cover and wipe the platen with a soft cloth dampened with alcohol or mild neutral detergent.

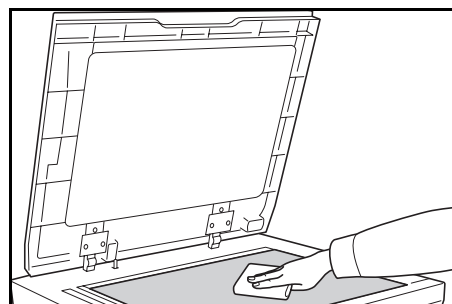

Important! Never use thinner or other organic solvents.

Cleaning the Slit Glasses

If copies appear soiled, such as black lines appearing on the copy image while using the optional document processor, the slit glasses **A** and **B** are dirty. Wipe the slit glasses with a dry soft cloth.

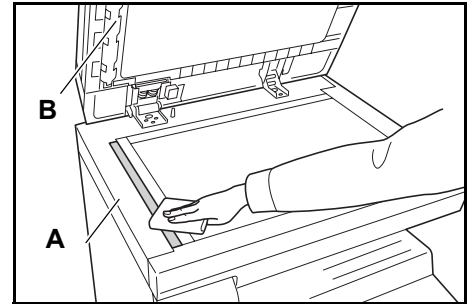

Important! Never use water, thinner, organic solvents or alcohol.

Note For cleaning the inside of the main body, see *Replacing the Toner Container and the Waste Toner Box* on page 6-5.

Cleaning the Separation Needle

- 1 Open the front cover.

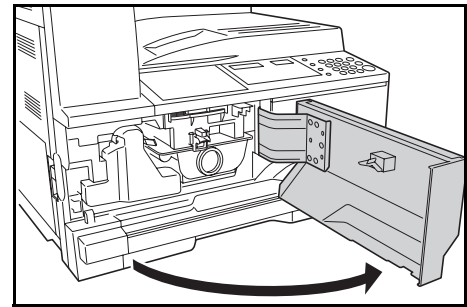

- 2 Remove the cleaning brush.

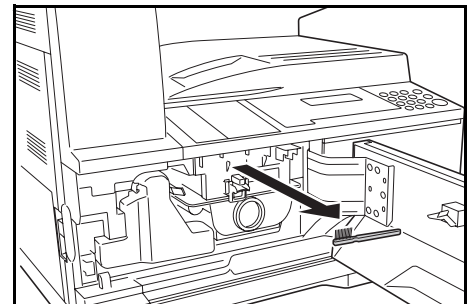

- 3 Pull the left cover handle up to open the cover.

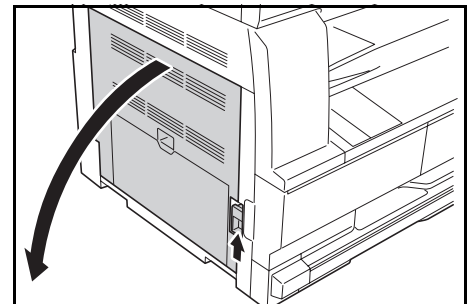

- 4 Move the brush from the left side to the right side along the separation needle as shown in the illustration to remove any dirt or dust.

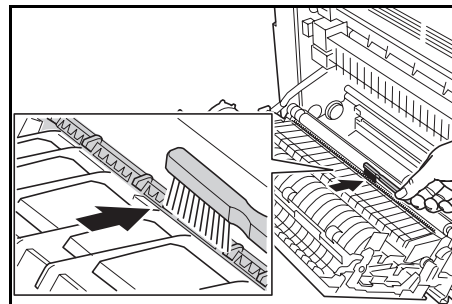

- 5 Close the left cover.

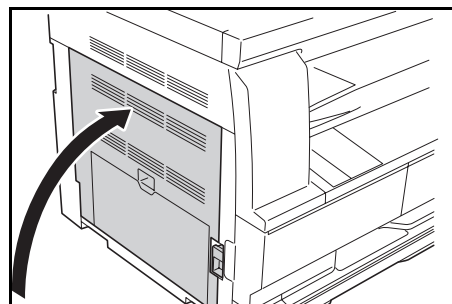

Cleaning the Transfer Roller

- 1 Open the front cover.

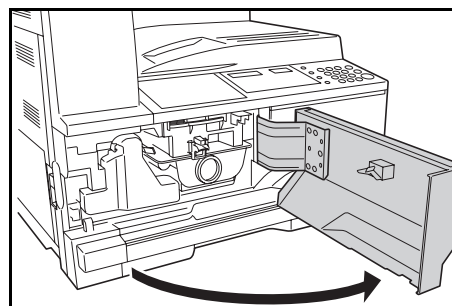

- 2 Remove the cleaning brush.

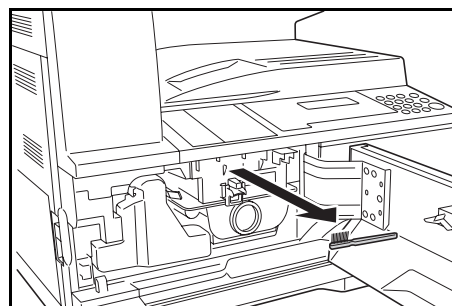

- 3 Pull the left cover handle up to open the cover.

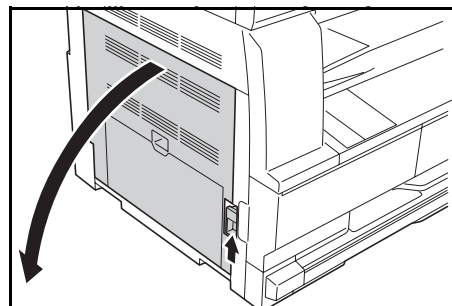

- 4** While turning the left transfer roller gear to turn the roller as shown in the illustration, move the brush from the left side to the right side along the roller to remove any dirt or dust.

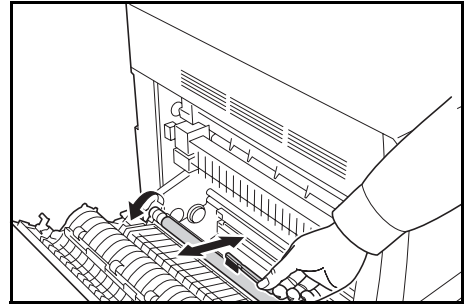

- 5** Close the left cover.

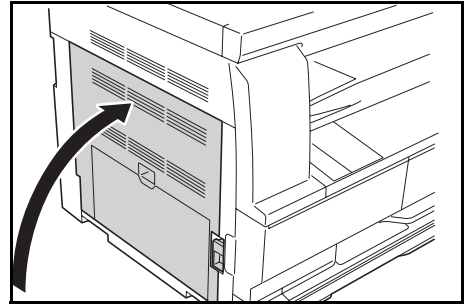

Replacing the Toner Container and the Waste Toner Box

When message `Add toner` is displayed on the message display the machine stops. Replace the toner container together with the waste toner box.

Notes Add toner only when `Add Toner` is displayed on the message display.

Whenever the toner container is changed, be sure to carry out the procedure described from step 7 on page 6-7 through step 11 on page 6-7. If any section is left dirty, the performance of this product cannot be maintained.

Caution

Do not attempt to incinerate the toner container or the waste toner box. Dangerous sparks may cause burns.

Caution

Do not attempt to force open or destroy the toner container or the waste toner box.

- 1 Open the front cover.

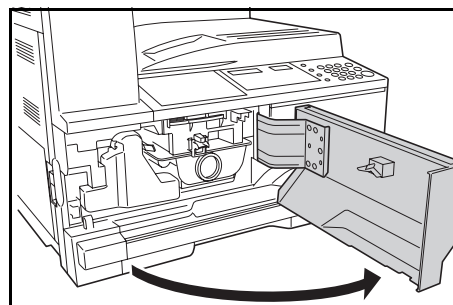

- 2 While pushing the waste toner box holder to the left, remove the waste toner box.

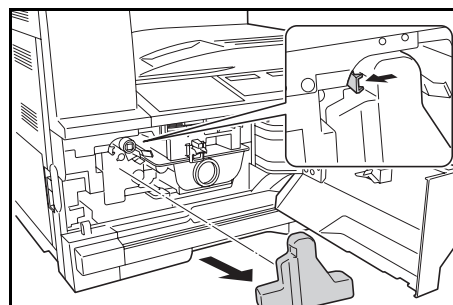

Important! Do not invert the old waste toner box.

Warning

High voltage is present in the charger section. Take sufficient care when working in this area, as there is a danger of electrical shock.

- 3 Use the cap attached to the center of the old waste toner box to cover the opening.

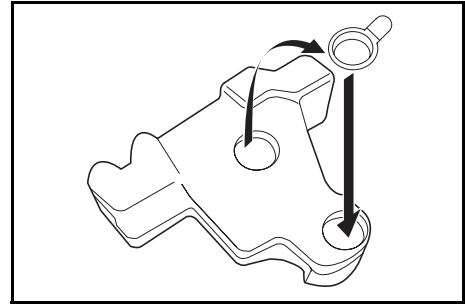

- 4 Turn the toner container release lever **A** to the left to pull out the toner container.

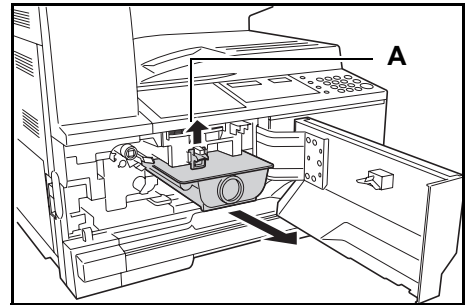

 **Caution**
Do not attempt to incinerate the toner container or the waste toner box. Dangerous sparks may cause burns.

 **Caution**
Do not attempt to force open or destroy the toner container or the waste toner box.

- 5 Place the old waste toner box in the plastic bag provided for disposal.

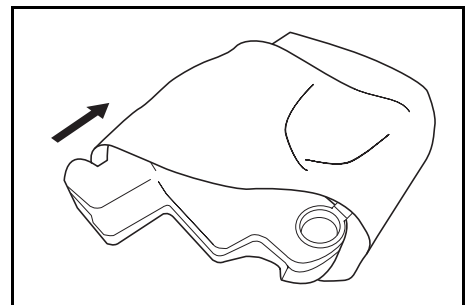

- 6 Place the old toner container in the plastic bag provided for disposal.

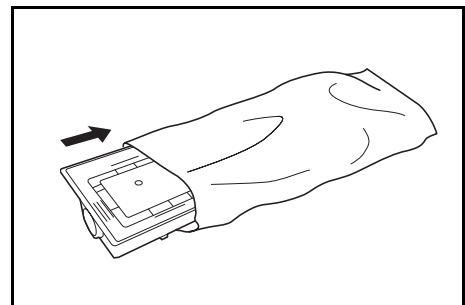

- 7** While holding the charger cleaner rod, gently pull it out as far as it will go and push it in again.
Repeat this operation two or three times.

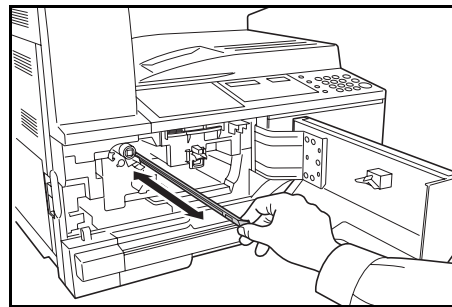

Note Do not use excessive force to pull the rod or attempt to pull it out completely.

- 8** While pushing the electrical charge section to the right, pull it out approximately 5 cm (2 inches).

Remove the accompanying grid cleaner from its package and remove its cap.

Fit the grid cleaner to the notch and install it into the main body.

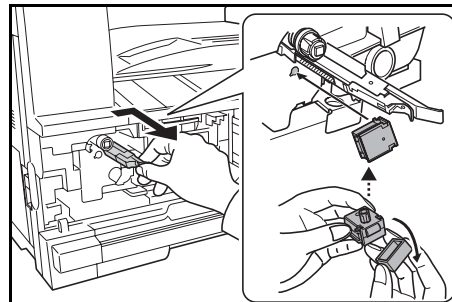

- 9** While holding gently the grid cleaner with your left hand, pull out the electrical charge section as far as it will go and push it back until the portion **B** does not touch the white pad of the grid cleaner.
Repeat this operation several times.

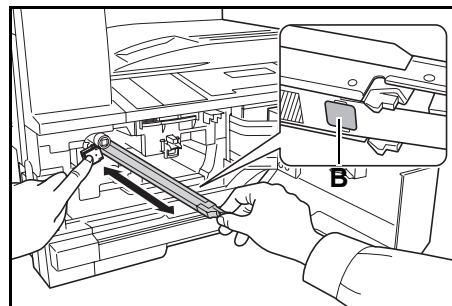

Important! When pushing back the electrical charge section, do not push it all the way into the main body. Copying trouble may occur.

- 10** When the electrical charge section is pulled out approximately 5 cm (2 inches), remove the grid cleaner and then push back the electrical charge section all the way into the main body.

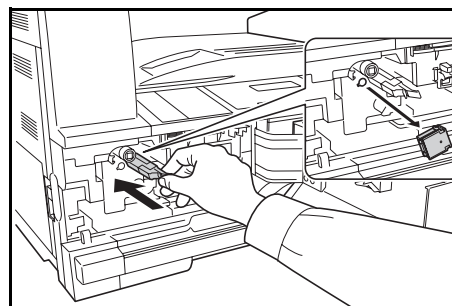

Important! After you use the grid cleaner to clean the electrical charge section, the machine can be used again after more than 5 minutes have elapsed.

- 11** Hold the new toner container vertically and tap the upper part five times or more.
Turn the toner container upside down and tap the upper part five times or more.

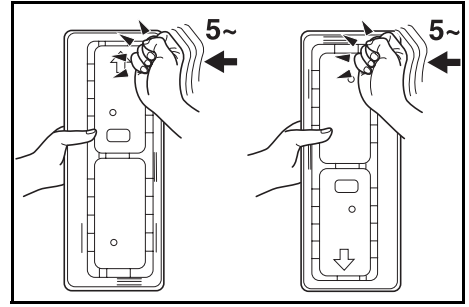

- 12** Shake the toner container up and down five times or more.
Turn the toner container upside down and shake it five times or more.

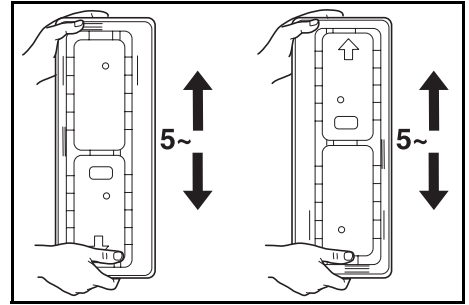

- 13** Hold the toner container horizontally and shake it from side to side five times or more.

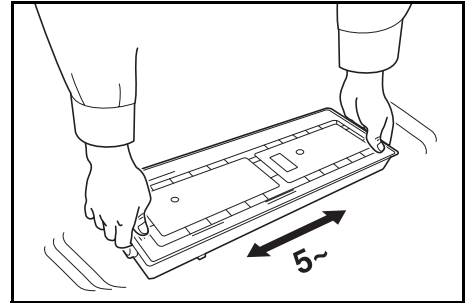

- 14** Insert the new toner container. Press it with both hands until it is locked.

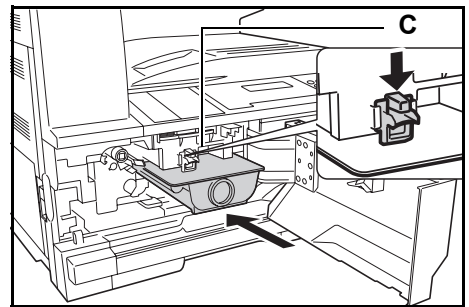

- 15** Install the new waste toner box.

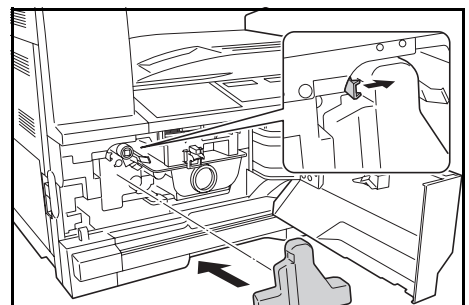

- 16** Close the front cover.

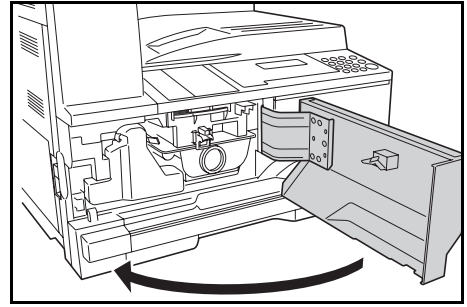

After use, always dispose of the toner container and the waste toner box in accordance with Federal, State and Local rules and regulations.

7 Troubleshooting

If Trouble Occurs

If trouble occurs with this machine, carry out the items indicated below. If the trouble persists, contact your service representative.

Symptom	Items to check	Corrective procedure	Reference page
Nothing is displayed on the operation panel when the main power switch is turned on.	Is the power plug connected to an AC outlet?	Connect the plug to an AC outlet.	3-1
No copies come out when the Start key is pressed.	Is there any indication of the trouble on the operation panel?	Check the appropriate measures against that indication and carry out the corresponding procedure.	7-4
The copies come out blank.	Were the originals set correctly?	When setting originals on the platen, set them face-down along the original size indicator plates.	3-1
		When setting originals in the optional document processor, set them face-up.	2-11
The copies come out too light.	Is the auto density adjustment mode set?	To adjust the overall density level, perform the auto density adjustment procedure.	-
	Is the manual density mode set?	Use the Lighter key or the Darker key to adjust the density level properly.	3-2
		To adjust the overall density, perform the relevant density adjustment procedure in each image quality mode.	-
	Is the toner evenly distributed in the toner container?	Shake the toner container horizontally approximately 10 times.	6-5
	Is the EcoPrint mode set?	Do not set the EcoPrint mode.	-
	Is Adding Toner requested?	Replace the toner container.	6-5
	Is the copy paper wet?	Replace the copy paper with new paper.	2-1
	Is the electrical charge section dirty?	Open the front cover and use the charger cleaner rod to clean the electrical charge section.	6-7
The copies come out too dark.	Is the auto density adjustment mode set?	To adjust the overall density level, perform the auto density adjustment procedure.	-
	Is the manual density mode set?	Use the Lighter key or the Darker key to adjust the density level properly.	3-2
		To adjust the overall density, perform the relevant density adjustment procedure in each image quality mode.	-

Troubleshooting

Symptom	Items to check	Corrective procedure	Reference page
A moire pattern (the phenomenon where the dots do not appear to be lined up properly but seem to be grouped together in patterns) appears on the copies.	Is the original a printed photograph?	Set the image quality mode to Photo .	3-1
The copies are not clear.	Did you select an image quality mode properly according to the type of the original?	Select an appropriate image quality mode.	3-1
The copies are dirty.	Is the platen or the original cover dirty?	Clean the platen and/or the original cover.	6-2
The copy image is skewed. Were the originals set correctly?		When using the platen, set the original securely along the original size indicator plates.	3-1
		When using the optional document processor, adjust the original insert guides securely before setting the originals.	2-11
	Was the paper set correctly?	Check the width guide plate position in the cassette.	2-1
Paper jams occur often.	Is the paper loaded properly in the cassette?	Load the paper properly.	2-1
		Depending upon the type and storage condition of the paper, finished copies may curl tightly, resulting in a paper jam. Remove the paper from the cassette, turn it over, and set it in the cassette again.	—
	Is the paper curled, folded over or wrinkled?	Replace the paper with new paper.	2-1
	Is there any jammed paper or loose scraps of paper remaining inside the machine?	Carry out the appropriate procedure to remove the paper.	7-8
	Does the size of the paper set in the multi-purpose tray match the registered size?	Make sure the size of the paper set in the multi-purpose tray matches the registered size.	2-4
Black lines appear on copies when copying from the optional document processor.	Is the slit glass dirty?	Clean the slit glass.	6-2
		It is also possible to use the black line correction function to make any black lines on the copies less apparent.	-
Wrinkling occurs in copies.	Is the separation needle dirty?	Clean the separation needle.	6-2
Black or white vertical lines appear on copies.	Is the electrical charge section dirty?	Open the front cover and use the charger cleaner rod to clean the electrical charge section.	6-7
White spots appear on copies.	Is the transfer roller dirty?	Clean the transfer roller with the cleaning brush.	6-3

Symptom	Items to check	Corrective procedure	Reference page
Copies are blurred.	Is this machine used at high humidity?	Perform drum refresh.	-
The copies are curled.	Is the copy paper wet?	Replace the copy paper with dry, new paper.	2-1
	Is <code>Middle 2</code> set at the Paper type (Paper Weight) setting? (Normally, <code>Middle 2</code> is set.)	Set <code>Middle 1</code> at the Paper type (Paper Weight) setting.	-

Responding to Error Messages

If the touch panel displays any of these messages, follow the corresponding procedure.

Alphanumeric

Display	Corrective Procedure
Add paper in cassette #.	There is no paper in the cassette. Load paper into the cassette as displayed in place of #.
Add toner.	Copies cannot be produced because there is no toner. Replace the toner container with a new one.
Cannot copy this orig. size.	<p>An original size that cannot be copied has been set. Check the original.</p> <ul style="list-style-type: none"> • The original was set in a vertical direction during the Book Border Erasure copying operation. Set the original horizontally. • An irregular size original was set during the Border Erase or Combine mode operation. • An original size other than Letter, Ledger, A3, A4R, A5R, B4 or B5R was set to make a split copy or a 2-Sided Copy from a double-page spread original.
Cannot duplex this paper size	A size that cannot be copied on both sides has been specified. 2-Sided copies cannot be taken when A6R, B6R, Postcard, Irregular Size or the paper size has not been specified. Specify a paper size that can be used.
Call service. C####	Make a note of the C and the number (C# # # #). Turn the power switch OFF, unplug the power cord and contact your service representative.
Close document processor.	The Document Processor is open. Close the Document Processor.
Close document processor cover.	The left cover of the Document Processor is open. Close the left cover. Close the front cover.
Close front cover.	The front cover of the copier is open. Close the front cover.
Close left cover #.	The left cover of the cassette is open. Close the left cover as displayed in place of #.

Display	Corrective Procedure
<div style="border: 1px solid black; padding: 5px; width: fit-content;">Insert key counter.</div>	<p>Check the key counter and make sure it is set properly.</p>
<div style="border: 1px solid black; padding: 5px; width: fit-content;">No matching paper available.</div>	<p>No Letter/A4 size paper was available in either the cassette or the Paper Feeder (MP tray) at the time when the report was attempted to be output. Press the Paper Selection key and select the supply cassette, then press the Start key. Paper will be supplied from the cassette selected.</p>
<div style="border: 1px solid black; padding: 5px; width: fit-content;">MainPower Off/On A####</div>	<p>Turn the power switch OFF/ON. Usage will be possible again once the regular display returns. When A and the number (A# # # #) are again displayed, make a note of the A and the number. Turn the power switch OFF, unplug the power cord and contact your service representative.</p>
<div style="border: 1px solid black; padding: 5px; width: fit-content;">Memory is full. Cannot continue.</div>	<p>Copies cannot be produced because memory is full during the interrupt copy operation. Interrupt Copying cannot be carried out so press the Stop/Clear key and then press the Interrupt key again after the data read in has been deleted to exit the Interrupt Copying. After the copying operation for the interrupted copy has been completed, repeat the procedure again.</p>
<div style="border: 1px solid black; padding: 5px; width: fit-content;">Memory is full. Press OK.</div>	<p>Memory is full. Press the OK key to start outputting the copies read in. Press the Reset key or the Stop/Clear key to delete the data read in. Reduce the number of originals and repeat the copying procedure.</p>
<div style="border: 1px solid black; padding: 5px; width: fit-content;">MP tray empty. Add paper.</div>	<p>Check the MP Tray paper. Set paper in the MP Tray in the event there is no paper present there. When the MP Tray paper fails to be fed, reset the paper.</p>
<div style="border: 1px solid black; padding: 5px; width: fit-content;">Paper jam</div>	<p>A paper misfeed has occurred. Remove the jammed paper.</p>
<div style="border: 1px solid black; padding: 5px; width: fit-content;">Place orig on doc processor</div>	<p>The copier will try to make copies of the originals it could not copy before. Return all of the originals to the original table and try copying them again.</p>
<div style="border: 1px solid black; padding: 5px; width: fit-content;">Replace waste toner box.</div>	<p>The waste toner box is full. Replace it with a new waste toner box.</p>
<div style="border: 1px solid black; padding: 5px; width: fit-content;">Remove paper on top tray; Start.</div>	<p>250 copies have been stored on output tray. Remove the paper, press the Start key and resume copying.</p>

Display	Corrective Procedure
<div style="border: 1px solid black; padding: 5px; width: fit-content;"> Reseat originals on DP. </div>	Originals were set in the optional Document Processor when copying on 2-sides (front and back sides), when copying from the platen in 2-Sided copy, 2 in 1, 4 in 1 or when collating copies. Remove the originals from the Document Processor, replace the originals on the Original Table after exiting the front and back copying, 2-Sided copy, 2 in 1, 4 in 1 or Collate Mode and resume copying.
<div style="border: 1px solid black; padding: 5px; width: fit-content;"> Return all originals to DP. </div>	If the optional Document Processor is being used, there are originals left on the original table. Remove the originals, return them to the original table and try copying them again.
<div style="border: 1px solid black; padding: 5px; width: fit-content;"> Set paper cassette. </div>	Check the paper cassette that corresponds to the lighting indicator. Set the cassette.
<div style="border: 1px solid black; padding: 5px; width: fit-content;"> Shake the toner container. </div>	Tap and shake the new toner container without spilling the toner, and install it again.
<div style="border: 1px solid black; padding: 5px; width: fit-content;"> Set toner container. </div>	The Toner Container has not been set. Set the Toner Container.
The Add Toner indicator blinks on and off.	There is very little toner remaining. Copying can be continued for a short while before running out of toner. Prepare the toner container.
The Periodic Maintenance indicator blinks on and off.	This is a notification that the time for periodic maintenance is approaching.
The Periodic Maintenance indicator lights up.	It is time for Periodic Maintenance. Contact your service representative.
“= = =” appears on the copy quantity display.	Job Accounting being set. Use the numeric keys to enter the assigned Section Code to perform copying operations. Press the Logout key after copying is finished to display “= = =” again.
“-” appears on the copy quantity display.	The copier is in the Sleep Mode setting. Press the Energy saver key to exit the mode.
“--” appears on the copy quantity display.	The copier is in the Low Power mode setting. Press any key to exit the mode or in the case where the optional Document Processor is installed, set an original in the Document Processor.

Clearing Paper Jams

Stop copying operations when a paper misfeed occurs. When a paper misfeed occurs, the indicator for the location of the paper misfeed will light up on the Operation Panel and either “J” plus a 2-digit number will be displayed as notification of the location of the paper misfeed.

With the Power Switch in the ON (I) position, clear the paper misfeed.

Clearing Paper Jams

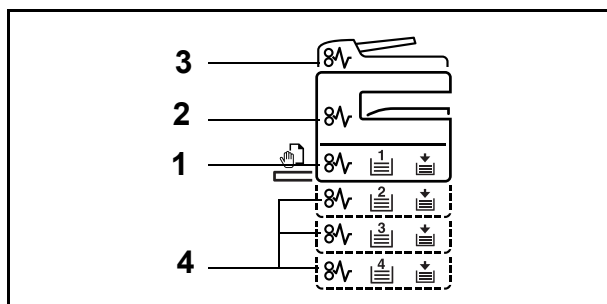

Paper Jam Location Indicator	Paper Jam Location	Reference Page
1	Paper supply section	7-2
2	Left cover internal section	7-10
3	Optional Document Processor	7-12
4	Optional cassette	7-9

After you remove the jam, the machine will warm up again and the error message will be cleared. The machine resumes with the page which jam has occurred.

Precautions with Paper Jams

- Do not reuse jammed papers.
- If the paper tears during removal, be sure to remove any loose scraps of paper from inside the machine. Scraps of paper left in the machine could cause subsequent jamming.
- Discard paper that has jammed in the optional document finisher. A page affected by a paper jam will be printed again.



CAUTION: High voltage is present in the charger section. Take sufficient care when working in this area, as there is a danger of getting burned.



CAUTION: The fixing unit is extremely hot. Take sufficient care when working in this area, as there is a danger of getting burned.

Notes

 **Warning**

High voltage is present in the charger section. Take sufficient care when working in this area, as there is a danger of electrical shock.

 **Caution**

The fixing unit is extremely hot. Take sufficient care when working in this area, as there is a danger of getting burned.

- Do not reuse jammed paper.
- If paper is torn during removal, be sure to remove any loose scraps of paper from inside the machine. Failure to do so may cause another paper jam later.
- Once all jammed paper has been removed, warm-up will begin. The error message will disappear and the machine will return to the same settings as prior to the paper jam.

Removal Procedures

J11, J21: Paper Jam inside Cassette 1

Perform the following procedure to remove the jammed paper.

- 1 Pull out the cassette.

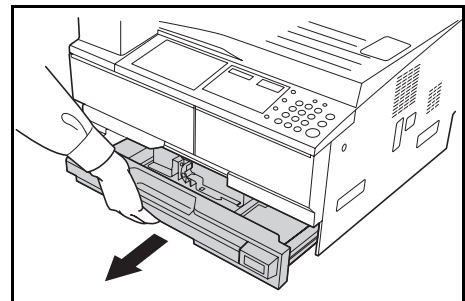

- 2 Remove any jammed paper without tearing it.

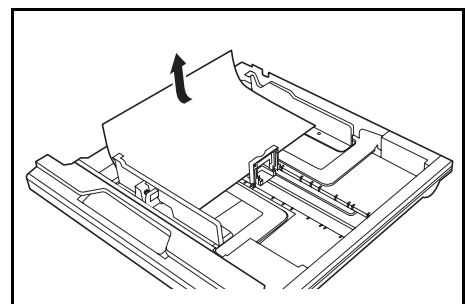

Note If the paper does happen to tear, remove any loose scraps from inside the machine.

- 3 Push the cassette back in firmly.

- Notes**
- Check to see if paper is out of position in the cassette. If the paper is out of position, set the paper properly.
 - If JAM21 is displayed, remove the jammed paper referring to **J20 to J50, J52 to J57, J60, J61: Paper Jam in the Left Cover** on page 7-10.

J12 to J16, J22 to J24: Paper Jam inside Cassettes 2 to 4

Perform the following procedure to remove the jammed paper.

- 1 Open the left cover of the cassette being used.

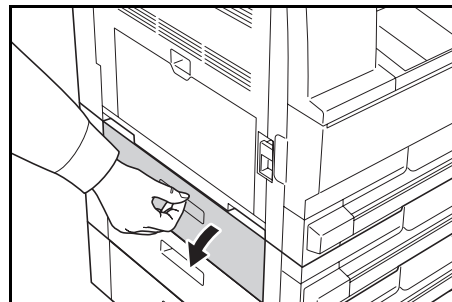

- 2 Remove any jammed paper without tearing it.

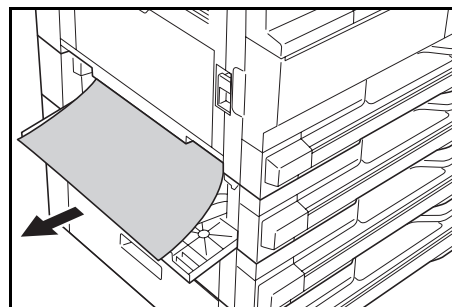

Note If the paper does happen to tear, remove any loose scraps from inside the machine.

- 3 Close the left cover of the cassette.

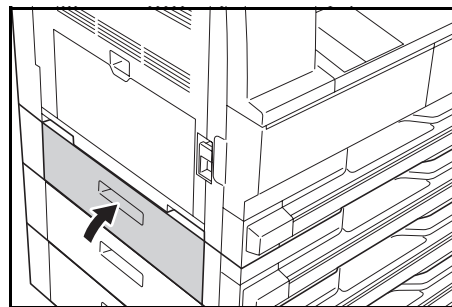

- 4 Pull out the cassette.

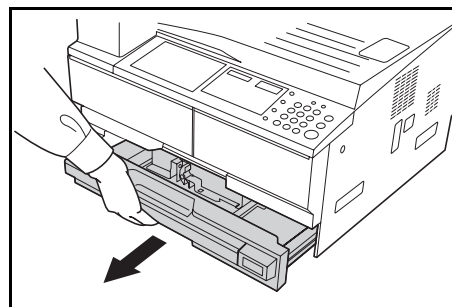

- 5 Remove any jammed paper without tearing it.

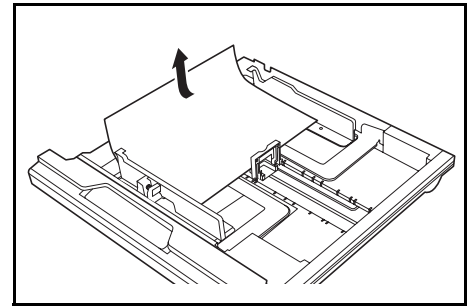

Note If the paper does happen to tear, remove any loose scraps from inside the machine.

- 6 Push the cassette back in firmly.

J10: Paper Jam in the Multi-Purpose Tray

Perform the following procedure to remove the jammed paper.

- 1 Remove all of the paper remaining in the multi-purpose tray.

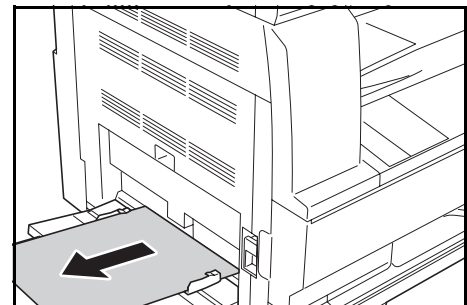

- 2 Reset the paper in the multi-purpose tray. The error message disappears.

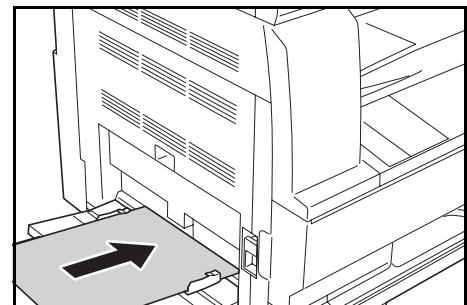

Paper Jam in the Multi-Purpose Tray (except J10)

- Important!**
- If J20 is displayed, remove the jammed paper referring to **J20 to J50, J52 to J57, J60, J61: Paper Jam in the Left Cover.**
 - If J40 is displayed, remove the jammed paper referring to **J20 to J50, J52 to J57, J60, J61: Paper Jam in the Left Cover.**
 - When removing jammed paper, do not pull it out from the multi-purpose tray side.

J20 to J50, J52 to J57, J60, J61: Paper Jam in the Left Cover

Perform the following procedure to remove the jammed paper.

- Important!** The drum section inside the main body is sensitive to scratches and contaminants. When removing paper, be careful not to touch it or scratch it with your watch, ring, etc.

- 1 Pull the left cover handle up to open the left cover.

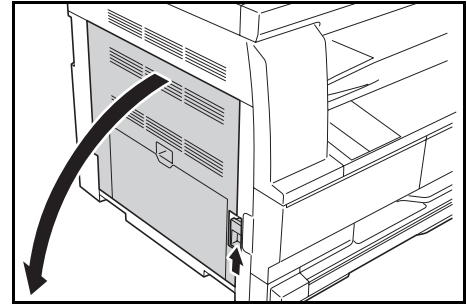

Caution

The fixing unit is extremely hot. Take sufficient care when working in this area, as there is a danger of getting burned.

- 2 Remove any jammed paper without tearing it.

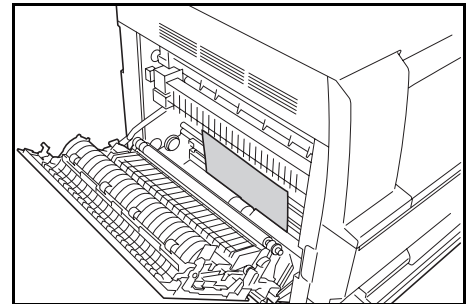

Note If the paper does happen to tear, remove any loose scraps from inside the machine.

- 3 If the optional duplex unit is installed, raise the duplex unit and remove any paper.

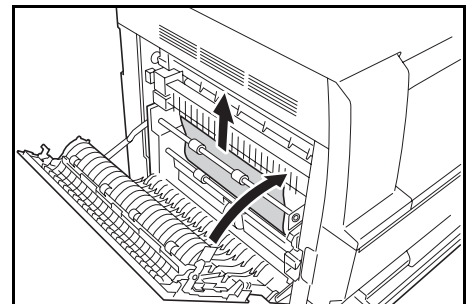

Note If the paper does happen to tear, remove any loose scraps from inside the machine.

- 4 Close the left cover.

J50: Paper Jam in the Paper Output Slot

Perform the following procedure to remove the jammed paper.

Important! The drum section inside the main body is sensitive to scratches and contaminants. When removing paper, be careful not to touch it or scratch it with your watch, ring, etc.

- 1 If jammed paper is seen through the paper output slot, pull it out to remove it.

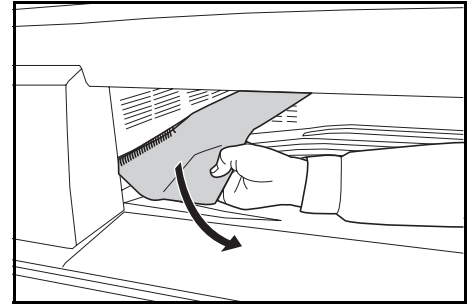

Note If the paper does happen to tear, remove any loose scraps from inside the machine.

- 2 Pull the left cover handle up to open the left cover.

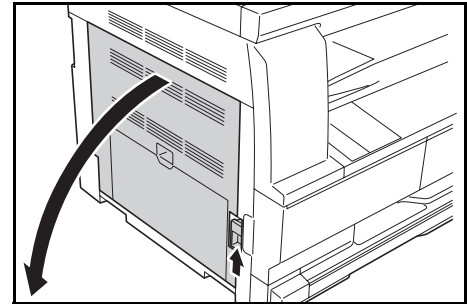

- 3 Remove any jammed paper without tearing it.

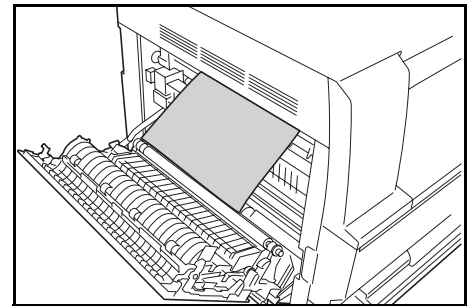

Note If the paper does happen to tear, remove any loose scraps from inside the machine.

- 4 Close the left cover.

J70 to J75 and J78: Paper Jam in the Optional Document Processor

Perform the following procedure to remove the jammed original(s).

- 1 Remove all of the originals remaining in the original table.

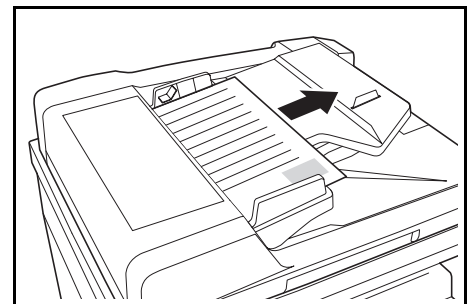

- 2 Open the left cover.

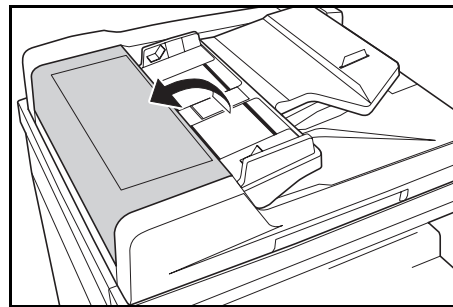

- 3 Remove any jammed original without tearing it.

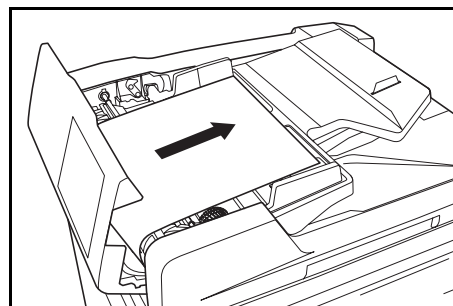

Note If the original does happen to tear, remove any loose scraps from inside the document processor. Failure to do so may cause another paper jam later.

- 4 Raise the paper feed unit **A**.

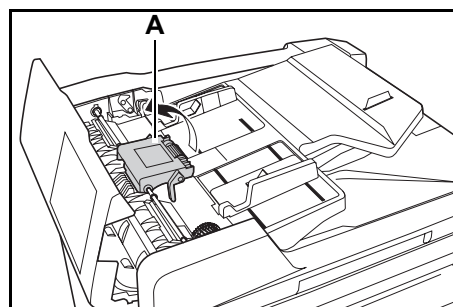

- 5 Remove any jammed originals without tearing them.

Note If the original does happen to tear, remove any loose scraps from inside the document processor.

- 6 Turn the dial as shown in the illustration to remove the jammed original.

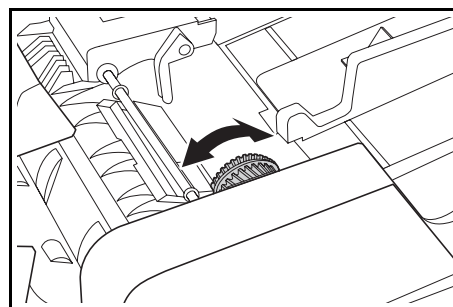

- 7 Close the left cover to its original position.
Reset all the originals and start copying again.

Appendix

Specifications

Note Specifications are subject to change without notice to reflect improvements in performance.

Main Body

Copying system	Indirect electrostatic system
Original types accommodated	Sheets, books, and 3-dimensional objects (maximum original size: A3/11 × 17")
Copy sizes	
Cassette	A3, B4, A4, A4R, B5, B5R, A5R, Folio, 11 × 17" (Ledger), 8 1/2 × 14" (Legal), 11 × 8 1/2", 8 1/2 × 11" (Letter), 5 1/2 × 8 1/2" (Statement), 8 1/2 × 13" (Oficio II), 8K, 16K
Multi Purpose tray	A3 to A6R, postcard, Folio, 11 × 17" (Ledger) to 5 1/2 × 8 1/2" (Statement), 8K, 16K
Width that cannot be copied	0.5 to 5.5 mm
Paper feed source capacity	
Cassette	300 sheets (80 g/m ²), 150 sheets (90 g/m ² and above)
Multi Purpose tray	100 sheets (80 g/m ²) (25 sheets for A3, B4, Folio, 11 × 17" (Ledger), 8 1/2 × 14" (Legal), 8 1/2 × 13" (Oficio II), and 8K sizes)
Output tray capacity	250 sheets (80 g/m ²)
Warm-up time	17,2 seconds or less Time for recovery from low power mode: 10 seconds or less Time for recovery from sleep mode: 17,2 seconds or less (At room temperature: around 71.6 °F (22 °C), humidity: around 60 %)
Memory	
For copier	64 MB
Additional memory	16 MB, 32 MB, 64 MB, and 128 MB
Operating environment	
Temperature	10 to 32.5 °C
Relative humidity	15 to 80 %
Altitude	2,500 m maximum
Illumination	1,500 lux maximum
Power source	120 V AC, 60 Hz, 9.5 A 220 to 240 V AC, 50/60 Hz, 5.0 A
Dimensions (main unit) (W) × (D) × (H)	23 53/64 × 21 1/2 × 29 11/32" 568 × 546 × 502 mm
Weight	72.75 lb/33 kg
Required space (W) × (D)	40 7/8 × 25 13/64" 1038 × 640 mm

Copier Functions

Copying speed			
Platen (1:1)	18-ppm model	A3/11 × 17" (Ledger): 8 sheets/minute B4/8 1/2 × 14" (Legal): 8 sheets/minute A4/11 × 8 1/2": 18 sheets/minute A4R/8 1/2 × 11" (Letter): 13 sheets/minute B5: 16 sheets/minute	
First copy time	5.7 seconds or less (1:1, A4/11 × 8 1/2")		
Resolution	Scanning: 600 × 600 dpi Printing: 600 × 600 dpi		
Continuous copying	1 to 999 sheets		
Copying magnification	Any ratio from 25 to 400 % (1 % increments) and fixed magnifications.		

Document Processor (optional)

Original feed system	Automatic feeding
Acceptable originals	Sheets of paper
Original sizes	Max.: A3/11 × 17" Min.: A5R/5 1/2 × 8 1/2"
Original paper weight	45 g/m ² to 160 g/m ²
Acceptable number of originals	50 sheets (50 g/m ² to 80 g/m ²) Mixed original sizes (auto select) 30 sheets (50 to 80 g/m ²) maximum
Mixed original sizes (auto select)	30 sheets (50 to 80 g/m ²) maximum
Dimensions (W) × (D) × (H)	21 47/64 X 18 1/64 X 4 47/64 552 × 483 × 120 mm
Weight	Approx. 13.2 lb./6 kg

Paper Feeder (optional)

Paper feed system	Automatic feeding from cassettes (300-sheet [80 g/m ²] capacity)
Paper sizes	A3, B4, A4, A4R, B5, B5R, A5R, Folio, 11 × 17" (Ledger), 8 1/2 × 14" (Legal), 11 × 8 1/2", 8 1/2 × 11" (Letter), 5 1/2 × 8 1/2" (Statement), 8 1/2 × 13" (Oficio II), 8K, 16K
Acceptable paper	Weight: 64 to 105 g/m ² Types: Standard paper, recycled paper
Dimensions (W) × (D) × (H)	568 × 546 × 135 mm
Weight	Approx. 6 kg

Duplex Unit (optional)

System	Internal type
Paper sizes	A3, B4, A4, A4R, B5, B5R, A5R, Folio, 11 × 17" (Ledger), 8 1/2 × 14" (Legal), 11 × 8 1/2", 8 1/2 × 11" (Letter), 5 1/2 × 8 1/2" (Statement), 8 1/2 × 13" (Oficio II), 8K, 16K, 16KR
Acceptable paper	Weight: 64 to 80 g/m ² Types: Standard paper, recycled paper
Dimensions (W) × (D) × (H)	14 19/64 × 2 9/64 × 7 9/64 368 × 54 × 181 mm
Weight	Approx. 0.5 kg

Environmental Specifications

Recovery time from the low power mode	10 seconds
Recovery time from Sleep mode	17,2 seconds or less
Transition time to the low power mode (at time of purchase)	1 minute
Transition time to the sleep mode (at time of purchase)	1 minute
Duplex (2-sided) copying	Option
Paper feed	Recycled paper made from 100 % recycled pulp may be used with this product.

Note Please consult with your dealer or service representative for information on the recommended types of paper, etc.

System Menu

The copier will enter the System Menu after warm up has been completed or when the **Reset** key has been pressed. The settings automatically set for the copier in the System Menu are called the Default Settings. These settings can be freely changed to match the usage of the copier.

System Menu Items

The following are the System Menu Items.

Change the settings as necessary in order to achieve the most efficient use of the copier. The factory default setting is indicated by an asterisk (*).

System Menu Items	Description	Available settings
01.Copy Status	Outputs the content of the Default Settings.	---
02.Language	Set the language of the message display.	[Inch specifications] English* Francais Espanol Japanese Portugues [Metric specifications] English Deutsch Francais Espanol Italiano Русский
03.Image Quality	Sets the manuscript image quality that will be selected at the time the copier is turned on.	Text + Ph Dens.* Photo Density Text Density
04.Initial Dens.	Sets the copy exposure at the time the copier is turned on to Manual or Automatic. There will be no display when Photo Density has been selected in 03.Image Quality.	Manual* Auto
05.EcoPrint	Selects the initial value of the EcoPrint Mode when the power is turned on. The initial value of the Eco Mode can be set to on (Enable). Exposures will be lighter and less toner will be consumed when the EcoPrint Mode is used.	On: Enabled Off: Disabled*
06.Density steps	Changes the number of the adjustment steps for the copy's exposure. 0.5 - Setting this step enables even finer adjustment of the exposure.	1 Step* 0.5 Step
07.Auto Density	Adjusts the overall exposure of the copy when Auto Exposure Mode is used.	1(lightest) to 7(darkest) (*4)
08.Text+Ph Dens.	Adjusts the central exposure value for the copier's manual exposure (Text and Photo).	1(lightest) to 7(darkest) (*4)
09.Photo Density	Adjusts the central exposure value for the copier's manual exposure (Photo).	1(lightest) to 7(darkest) (*4)

System Menu Items	Description	Available settings
10.Text Density	Adjusts the central exposure value for the copier's manual exposure (Text).	1(lightest) to 7(darkest) (*4)
11.ReduceStreaks	It is possible to make black streaking less noticeable when it appears when using the optional Document Processor.	Off* Weak Strong
12.OptimizePhoto	Setting this to Error Diffusion when copying originals with text and photos and Dithering when copying originals with mainly photos will result in clearer images.	ErrorDiffusion* Dither Matrix
13.OptimizBackgr	The background color can be lightened when it is found to be too dark after copying.	1(lightest) to 5(darkest) (*3)
14.Initial Paper	Selects whether the cassette with the same size of paper as the original size will be automatically selected or whether a selected cassette level is to be used.	Auto* DefaultCassette
15.AutoSel Paper	Specifies the media type when the copier automatically selects the paper.	OFF Plain* Transparency Rough Vellum Labels Recycled Preprinted Bond Cardstock Color (Colour) Prepunched Letterhead Thick paper Envelope High Quality Custom 1 to 8
16.DefaultCasset	Selects the cassette that is automatically given priority for use. Manual paper feeding cannot be set using the Selected cassette function. Cassettes 2 to 4 will be displayed only when the optional Paper Feeder is installed.	Cassette 1* Cassette 2 Cassette 3 Cassette 4
17.AutoCassetSel	Switches feeding automatically to a cassette holding paper of the same size/orientation and copying continues when the paper in the cassette being used runs out. This will be displayed when the optional Paper Feeder is installed.	Disting. paper Not disting.*
18.PriorAutoZoom	Sets whether or not to use automatic magnification (zoom/reduction percentage) when a paper cassette has been selected.	On: Enabled Off: Disabled*

System Menu Items	Description	Available settings
19.Cassette1Size	<p>Automatically detects the paper size in the cassettes (1 to 4).</p> <p>When it is to be detected in inches, set this to AutoDetect inch; when the paper size is to be detected in centimeters, (A-B columns) set this to Auto Detect mm and when Oficio 2, 8K or 16K size is to be used, set this to Oficio 2, 8K or 16K.</p> <p>Cassettes 2, 3 and 4 will be displayed only when the optional Paper Feeder is installed.</p>	<p>Auto Detect mm (*Metric specifications)</p> <p>AutoDetect inch (*Inch specifications)</p> <p>Oficio 2</p> <p>8K</p> <p>16K</p>
20.Cassette2Size		
21.Cassette3Size		
22.Cassette4Size		
23.MPTray Config	<p>Sets the size of paper to be manually fed in.</p>	<p>Paper Size</p> <p>[Inch specifications]</p> <p>Universal size*</p> <p>Ledger R</p> <p>Legal R</p> <p>Letter R</p> <p>Letter</p> <p>Statement R</p> <p>Other Standards</p> <p>Customized Size</p> <p>[Metric specifications]</p> <p>Universal size*</p> <p>A3 R</p> <p>A4 R</p> <p>A4</p> <p>A5 R</p> <p>A6 R</p> <p>B4 R</p> <p>B5 R</p> <p>Folio R</p> <p>Other Standards</p> <p>Customized Size</p> <p>Media Type</p> <p>Plain*</p> <p>Transparency</p> <p>Preprinted</p> <p>Labels</p> <p>Bond</p> <p>Recycled</p> <p>Rough</p> <p>Vellum</p> <p>Letterhead</p> <p>Colour</p> <p>Prepunched</p> <p>Envelope</p> <p>Cardstock</p> <p>Thick Paper</p> <p>High Quality</p> <p>Custom (1 to 8)</p>

System Menu Items	Description	Available settings
24.Custom Size 1	Sets the size to be set to the Custom size (1 to 2). This makes it possible to set the sizes that do not appear on the operation panel.	[Inch specifications] A3 R A4 R A4 A5 R B4 R B5R B5 B6 R A6 R Hagaki 11 × 15" R Folio R Oficio 2 8K 16K 16KR Customized Size YYY × XXX (") Y-direction: 3.88 to 11.63" X-direction: 5.88 to 17" [Metric specifications] B5 E B6 R* A6 R Hagaki Ledgr R Legal R Letter R Letter Statement R Oficio 2 8K 16K 16KR 11 × 15" R Customied Size YYY × XXX (mm) Y-direction: 98 to 297mm X-direction: 148 to 432mm
25.Cusst Size 2		
26.Casst1MedType	Specifies the media type to the cassettes (1 to 4). Cassette 2, 3 and 4 will be displayed only when the optional Paper Feeder is installed.	Plain* Recycled Preprinted Bond Rough Color (Colour) Letterhead Prepunched High Quality Custom 1 to 8
27.Casst2MedType		
28.Casst3MedType		
29.Casst4MedType		

System Menu Items	Description	Available settings
30.CustmMedType1	Sets the paper weights and 2-sided copying to the Custom paper. 2-sided copying will be displayed only when the optional Duplex Unit is installed.	Paper weights Extra Heavy Heavy 3 Heavy 2 Heavy 1 Normal 3 Normal 2* Normal 1 Light (Vellum) 2-sided copying On: Enabled* Off: Disabled
31.CustmMedType2		
32.CustmMedType3		
33.CustmMedType4		
34.CustmMedType5		
35.CustmMedType6		
36.CustmMedType7		
37.CustmMedType8		
38.Hagaki/A6RDet	Select the paper size when copying an original document of non-standard size.	Hagaki A6 R*
39.B4R/Folio Det	Select the paper size when copying an original document of non-standard size.	B4 R Folio R*
40.11x15" Detect	When the size of the original document is 11 x 15", the original document is automatically zoomed.	On Off*
41.Copy Limit	Limits the number of copies or sets of copies that can be made at one time.	1 to 999 (*999)
42.Duplex 2nd	Rotates the paper 180 degrees and copies it when both sides of a sheet are to be copied. This will not be displayed when the optional Duplex Unit is not installed.	Rotation On Rotation Off*
43.Stitch Width	Sets the initial value for the Binding Margin.	[Inch specifications] 0.13/0.25/0.38/0.50/0.63/0.75 (" (*0.25) [Metric specifications] 1 to 18 (mm) (*6)
44.Border Erase	Sets the initial value for the border width that will be lightened to remove shadows from a sheet or book.	[Inch specifications] 0.13/0.25/0.38/0.50/0.63/0.75 (" (*0.25) [Metric specifications] 1 to 18 (mm) (*6)
45.4 in 1 Layout	Sets the layout for the order in which the originals will appear in the 4-in-1 Layout mode.	Portrait 1* Portrait 2 Landscape 1 Landscape 2
46.Combine Border	Selects the type of borderline to be used in the Layout mode.	Off* Solid Dotted
47.Rotate/Offset	Sets the copier so that each copy set is rotated and collated when it is collate copied.	On: Rotational Collating Enabled Off: Rotational Collating Disabled*
48.Auto Rotation	Sets of copied documents are output landscape/portrait alternately, allowing easy separation of each set from the other.	On: Enabled* Off: Disabled

System Menu Items	Description	Available settings
49.Silent mode	Shortens the amount of time the internal motor continues to run after the copy is produced. Use this setting in cases when the motor noise is bothersome.	0, 5, 10, 15, 30 (seconds) (*10)
50.Auto Clear	Sets the copier so that automatic clearing is executed after a set amount of time has elapsed after the copy is produced. (Refer to <i>Auto Clear function on page 1-6.</i>)	On: Enabled* Off: Disabled
51.Auto Sleep	The Auto Sleep mode will be entered after a set period of time has passed after the final copy has been produced or during which no operations have been performed. If the Auto Sleep function interferes with your copy operations, disable the function. Before disabling the Auto Sleep function, you may want to try lengthening the amount of time before the Auto Sleep function engages (Sleep Mode Transition Time).	On: Enabled* Off: Disabled
52.AutoClearTime	Sets the time interval prior to the automatic operation of the Auto Clear function when On (Enable) has been selected as the 50.Auto Clear setting. This will not be displayed when 50.Auto Clear is set to Off.	10 to 270 (10-second units) (*120)
53.LowPower Time	Sets the time interval prior to the automatic engagement of the Low Power mode after copy operations have been completed.	1, 5, 15, 30, 45, 60, 90, 120, 180, 240 (minutes) (*1)
54.AutoSleepTime	Sets the time interval prior to the automatic operation of the Auto Sleep function when On (Enable) has been selected as the 51.Auto Sleep setting. This will not be displayed when 51.Auto Sleep is set to Off.	1, 5, 15, 30, 45, 60, 90, 120, 180, 240 (minutes) (*1)
55.Alarm	The Alarm can be set to sound when a key on the Operation Panel is pressed or in cases when errors occur, etc.	On: Enabled (sound alarm) Off: Disabled (no alarm)*
56.CoverageRepo	Prints out a report that shows the number of copies made and the average amount of toner used (blackness ratio %) for each paper size.	---

System Menu Operation Procedures

Follow the procedures listed below to operate in the System Menu.

- 1 Press Exposure Adjustment keys on both sides for 3 seconds.

System Menu will be displayed.

- 2 Press \uparrow or \downarrow to select System Menu Items.

NOTE: Each of the System Menu Items can be selected by pressing the numeric keys.

Refer to "Procedure for Changing the Default Settings" regarding the following.

System Menu: 00.Setting done

- 3 After completing each operation, press \uparrow or \downarrow to display 00.Setting done, and then press the **OK** key.

NOTE: The message display will return to the Ready to copy. by pressing the **Reset** key. You can cancel the setting by pressing the **Stop/Clear** key.

Index

Numerics

2 in 1	3-11
4 in 1 (horizontal arrangement)	3-12
4 in 1 (vertical arrangement)	3-13

A

Additional memory	5-3
Auto Clear function	1-6
Auto low power function	3-15
Auto Sleep	3-16
Auto sleep function	3-16
Auto zoom ratio selection mode	3-3
Automatic Cassette Switching Function	1-7

B

Bypass tray extension	1-1, 2-5
-----------------------------	----------

C

Cassette	1-1, 2-2
Charger cleaner rod	1-2, 6-7
Cleaning	6-1
Cleaning the original cover	6-1
Cleaning the platen	6-1
Cleaning the separation needle	6-2
Cleaning the slit glass	6-2
Cleaning the transfer roller	6-3
Clearing the job accounting count	4-3
Combine copying	3-10
Copier functions	Appendix-2
Copy	3-1
Split copying	3-8
Custom Sizes	1-6

D

Deleting department ID codes	4-3
Department ID code registration	4-2
Document Processor	
How to load originals	2-12
Loading Originals	2-11
Not Supported Originals	2-12
Part Names	2-11
Document processor	5-1, Appendix-2
Duplex copying	3-5
Duplex unit	5-2, Appendix-3

E

Environmental specifications	Appendix-3
Error messages	7-4
Exposure	3-2

F	
Front cover	1-2
G	
Grounding the machine	ii-ix
H	
How to set job accounting	4-4
I	
If trouble occurs	7-1
Image quality mode	3-1
Interrupt Copying	3-14
J	
Job accounting	4-1
Operation procedures	4-2
K	
Key counter	5-3
L	
Language setting	2-14
Left cover	1-2
Loading paper	2-1
Loading paper into the cassette	2-2
Low power mode	3-15
M	
Main power switch	1-3, 2-13, 3-1
Maintenance	6-1
Making copies in job accounting mode	4-4
Multi-purpose tray	1-1, 2-4
N	
Names of parts	1-1
O	
Operation Panel	1-4
Operation panel	1-1
Option	5-1
Overview	5-4
Original	
Loading in the Document	
Processor	2-11
Placing on the Platen	2-10
Original cover	1-1
Output tray	1-1, 3-2
Overview of job accounting	4-1
P	
Paper feeder	5-2, Appendix-2

Paper jam	7-7
Jam location indicators	7-7
Precaution	7-7
Paper jam in the document processor	7-12
Paper jam in the left cover	7-10
Paper jam in the multi-bypass tray	7-10
Paper jam in the paper output slot	7-11
Paper jam inside cassette 1	7-8
Paper jam inside cassettes 2 to 4	7-9
Paper length adjusting tab	1-1, 2-3
Paper width adjusting tab	1-1, 2-2
Photo	3-2
Platen	1-2, 3-1
Placing Originals	2-10
Printer kit	5-3
Printing the job accounting list	4-3
R	
Resolution	Appendix-2
S	
Setting paper in the multi-bypass tray	2-4
Slider	1-1, 2-5
Sort copying	3-9
Specifications	Appendix-1
System Menu	1-6
System menu	
Items	Appendix-4
Operation procedures	Appendix-10
T	
Text	3-2
Text + Photo	3-2
Toner container	1-2, 6-5
Turning the power on	2-13
W	
Warm up	2-13, 3-1
Waste toner box	1-2, 6-5
Z	
Zoom copying	3-3
Zoom mode	3-4

MEMO

MEMO

MEMO

For best print results and machine performance, we recommend that you use only original UTAX supplies for your UTAX products.



